

Dyna-Tite System Benefits

- Its labor saving qualities have been shown to reduce installation time by up to 6 times when compared to traditional threaded rod.
- It provides a fast and strong solution to the task of hanging Mechanical and HVAC Systems.
- It allows the installer to position the hangers vertically or at an angle to the suspended object. Hanging at an angle will reduce the safe working load. Please see our "Effects of Hanging at Angles" chart on page 18.
- It is lightweight and easy to carry, and combines these qualities with the inherent strength of high tensile wire rope.
- Improves safety on the job. Carrying the product on the job site is easy and, in aerial situations, it reduces accident risk caused by falling materials.

For Rectangular Duct

Easily adjustable release pin

Reduces installation by 6x's!

Working Loads up to 1,100 lbs.

5:1 Safety Factor

Aviation grade wire rope

Applications

Dyna-Tite cable locks and wire rope can be used for suspension in a variety of ways to accommodate most mechanical and HVAC construction applications.

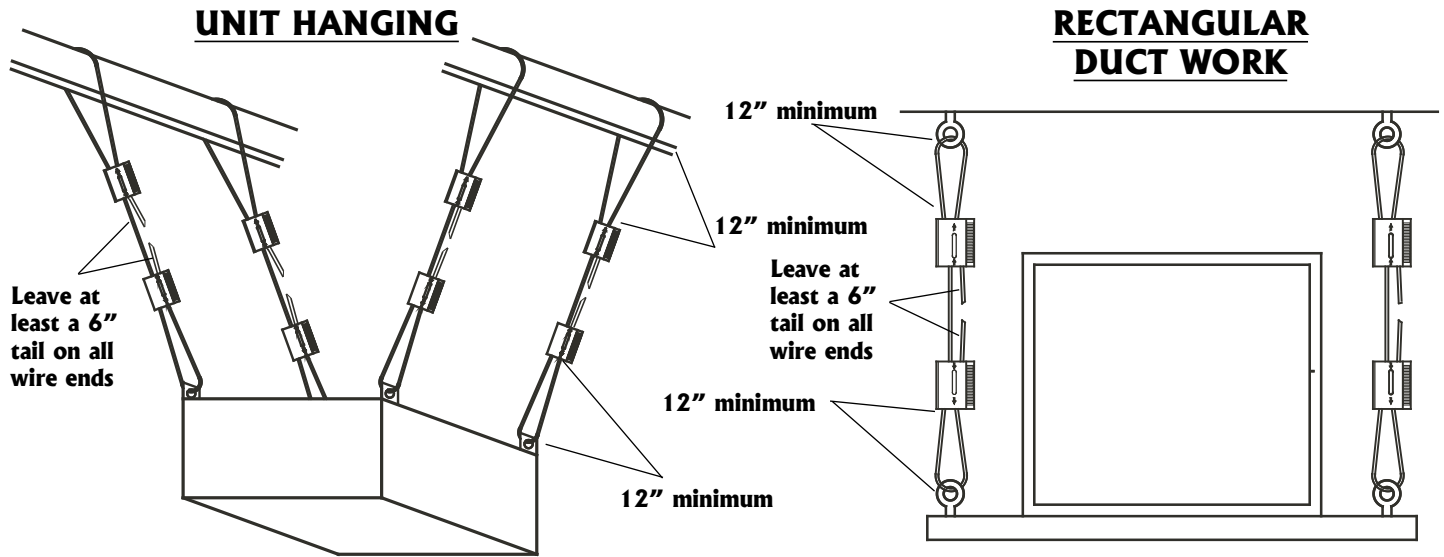

FIGURE 8 (CL23-WC6 ONLY)

