



**SOUTHWARK METAL MANUFACTURING COMPANY**

Philadelphia, PA • Greenville, SC • Indianapolis, IN • Southaven, MS • Fremont, NE • Caldwell, ID

Corporate Headquarters: 2800 Red Lion Road, Philadelphia PA 19114

tel: (800) 523-1052 • fax (800) 722-2076 • www.southwarkmetal.com

**SUBMITTAL DRAWING**

**AIR-TITE ROUND PIPE TAKEOFF with DAMPER, SCOOP and STANDOFF (MODEL NO: ATSDRPSO)**

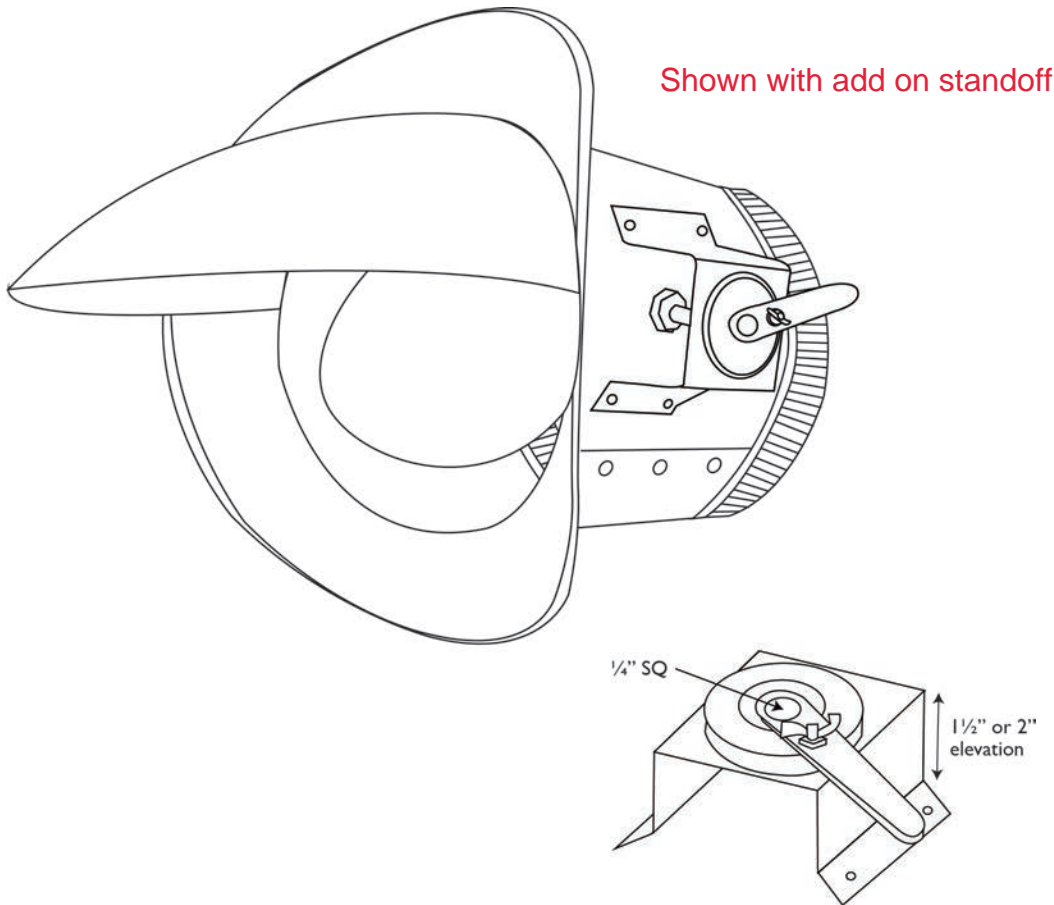

Collar Diameter	Pipe Size Range
3"	4" - 7"
4"	8" - 20"
5"	7", 9" - 20"
6"	6", 8", 20" 9" - 16"
7"	8", 9" - 14"
8"	8" - 14", 18"
9"	9", 14" - 16"
10"	10", 20", 24" 14" - 16"
12"	14" - 20", 24"
14"	18" - 22", 14"
16"	16" - 18", 24"
18"	20" - 24"
20"	20" - 24"

**NOTES**

- Material: Hot Dipped Galvanized Steel per ASTM A653 CS Type B
- 26 gauge
- 1/2" overlap with 1/8" rivets
- 1 1/4" crimp length
- 6 1/2" to 14 3/4" tube length
- Gasket 1 1/2" wide and 1/8" thick; made with high tack adhesive-coated neoprene foam
- Four 1/8" holes in gasket for sheet metal screw attachment
- Features a two quad damper (26 gauge with 18 gauge handle secured with wingnut)

JOB NAME: \_\_\_\_\_  
 LOCATION: \_\_\_\_\_  
 ARCHITECT: \_\_\_\_\_  
 ENGINEER: \_\_\_\_\_  
 CONTRACTOR: \_\_\_\_\_

DATE: 9/17/14    SW-ATSDRPSOSC    SD-0212  
 Air-Tite Round Pipe Takeoff with Damper, Scoop, and Standoff  
 MODEL NO: ATSDRPSO