

D U C T M A T E

ECONoflange™ Double Wall



Round Duct Connection System

Fast Screw Connection

- Simple installation process
- Can be installed on-site
- No special tools required
- Available in sizes 10" - 72" in standard 2" increments
- Available in specialty metals



DUCTMATE®

Industries, Inc.

ECONOflange™ Double Wall

Round Duct Connection System

DESCRIPTION

Round duct connection system.

BASIC USE

The ECONOflange Double Wall connection system was designed as an alternative round duct connection for applications in which appearance and performance are not paramount.

SPECIAL CHARACTERISTICS

Sizes

18 gauge cold-formed, hot-dipped galvanized steel is available for sizes 10" - 48".

16 gauge cold-formed, hot-dipped galvanized steel is available for sizes 50" - 72".

Gasket:

Ductmate Neoprene 5/16" x 3/4"

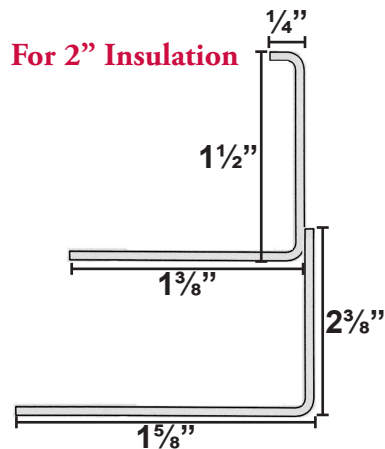
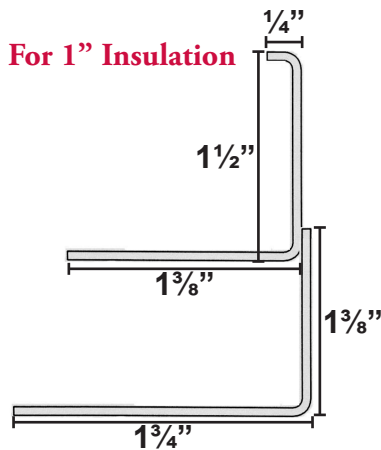

PACKAGING INFORMATION

The ECONOflange Double Wall connection system is sold in single rings.

INSTALLATION INSTRUCTIONS



1. ECONOflange Double Wall is manufactured with a split in the ring to allow for minor deviations in the diameter of the pipe.



2. Start the ring by inserting the 1 3/8" leg inside the duct.



INSTALLATION INSTRUCTIONS (Cont.)



3. Seat the ring flush with the end of the duct and clamp the ring into position.



6. Seal the joint internally with PROseal® duct sealant. Brush the sealer into the joint achieving a 100% seal.



7. The break in the flange will allow a portion of the leading edge of the duct to be visible. For a better seal on medium to high pressure jobs (4" and higher) it is preferred that a short piece of Ductmate 440 gasket be applied to the face of the flange to cover the leading edge on both mating flanges. (On low pressure jobs the 440, applied to the split, can be replaced by Ductmate Neoprene gasket.)



4. Begin securing the leg of the ring to the duct section at the split. Hold the flange in position by placing vise grips a few inches from the break. Begin placing a self drilling screw, spot weld, or line rivet $\frac{1}{2}$ " from the break.



5. Continue in one direction attaching the flange to the duct 1" from the face of the flange, 10" on center around the circumference of the duct. Optional stitch welding around ECONOflange Double Wall to duct 10" on center. Assure stitch welds cover 50% onto duct and 50% onto flange for strong weld.



8. Apply Ductmate Neoprene gasket $\frac{5}{16}$ " by $\frac{3}{4}$ " wide to the face of one of the ECONOflange Double Wall rings. The Neoprene should be positioned parallel to the inside of the ECONOflange Double Wall. The Neoprene gasket ends must be butted against each other.



INSTALLATION INSTRUCTIONS (Cont.)



9. Align mating frames be matching the ECONOflange Double Wall ring evenly around the circumference



ECONOflange Double Wall can be installed on reducing fitting in the same manner as a small end collar. This eliminates the need for collars unlike other traditional flange connection systems.



10. Clamp the mating ECONOflange Double Wall rings compressing the gasket until the mating rings touch.

11. Fasten self drilling screws 6" on center around the circumference of the flange face. In order to assure a proper closed joint, the rings should be clamped tightly together with the two faces touching each other prior to fastening the self drilling screw. Proper care should be taken in setting the clutch adjustment of your screw gun to assure your screws have 100% holding strength.

LIMITED PRODUCT WARRANTY

Ductmate warrants that ECONOflange™ Double Wall, when properly installed and maintained, will be free from defects in material and workmanship, and will comply with all written specifications made by Ductmate at the time of sale. Ductmate's warranty shall run for a period of one year from the date of manufacture.

Warranty Limitation

The warranty stated above is in lieu of all other warranties, express or implied, including but not limited to the implied warranties of MERCHANTABILITY AND FITNESS FOR A PARTICULAR PURPOSE. Although Ductmate may have suggested the product, or provided written or oral advice to the Purchaser, it is the Purchaser's responsibility to test and determine the suitability of ECONOflange™ Double Wall, for the intended use and purpose, and Purchaser and/or its customer assumes all risk and liability whatsoever regarding such suitability.

Limitation of Liability

In the event of a breach of the above warranty, Ductmate's sole obligation, and Purchaser's sole and exclusive remedy, shall be, at Ductmate's option, repair or replacement of any defective products, or refund of an applicable portion of the purchase price. Ductmate shall have no liability for costs of removal or reinstallation of the product. The Purchaser agrees that no other remedy, including but not limited to loss of profits, loss sales, injury to person or property, or any other special, incidental or consequential damages, shall be available to the Purchaser for any claim arising out of this Agreement, regardless of whether such claim is made in contract or in tort, including strict liability in tort. In no event will Ductmate be obligated to pay damages to the Purchaser in any amount exceeding the purchase price that the Purchaser paid to Ductmate for the allegedly defective product.



Charleroi, PA

210 Fifth Street
Charleroi, PA 15022
800-245-3188
724-258-0500
FAX: 724-258-5494

Lodi, CA

810 S. Cluff Avenue
Lodi, CA 95240-9141
800-344-3270
209-333-4680
FAX: 209-333-4678

www.ductmate.com



This spec data is printed on paper that meets the Certified Fiber Sourcing requirements of the SFI program and contains 10% recycled content

Distributed By:

Ductmate is a proud member of the following organizations:



© Copyright Ductmate Industries, Inc. All rights reserved.

673 - 04/15