

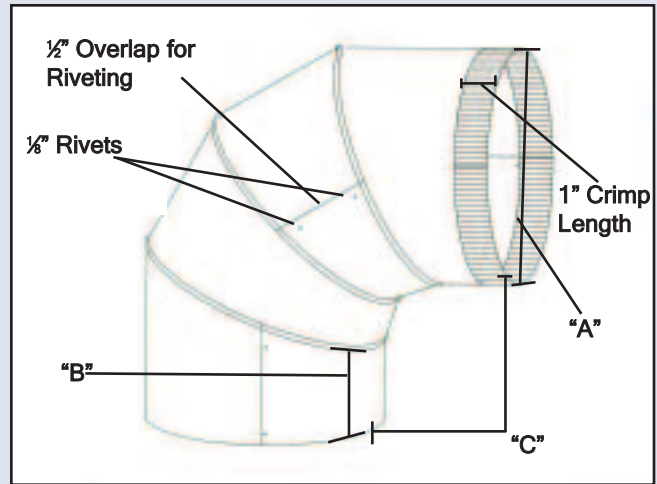

90° ADJUSTABLE ELBOW



SPECIFICATIONS:

Technical Data

- Material: Hot Dipped Galvanized Steel per ASTM A653 CS Type B
- Crimped Male Connection
- Straight Female Connection
- 3" thru 20" 4pc. Assembly
- 22" & 24" 5pc. Assembly
- 1/2" Overlap for Riveting using 1/8" Rivets
- 1" Crimp Length

"A" (Diameter)	"B"	"C" (Throat)
3"	1 1/2"	2 1/2"
4"	1 7/8"	3"
5"	1 3/4"	3"
6"	1 7/8"	3 1/8"
7"	2"	3 1/4"
8"	2"	3 3/8"
9"	2"	3 3/8"
10"	2 1/4"	4"
12"	1 5/8"	3"
14"	2 1/8"	4"
16"	2 1/4"	3 1/2"
18"	1 5/8"	3 1/2"
20"	1 7/8"	4 1/2"
22"	1 3/4"	5 1/2"
24"	2"	6 3/8"

Product Availability

Diameter	30 Ga	28 Ga	26 Ga	24 Ga
3"	X	X	X	
4"	X	X	X	X
5"	X	X	X	X
6"	X	X	X	X
7"	X	X	X	X
8"	X	X	X	X
9"	X	X	X	X
10"	X	X	X	X
12"	X	X	X	X
14"		X	X	X
16"			X	X
18"			X	X
20"			X	X
22"				
24"				

- Certain Sizes Also Available in:
Aluminum Type
Type 304 Stainless

SOUTHWARK METAL MFG CO

Philadelphia Division (800) 523-1052 * Greenville Division (800) 229-2803 * Indianapolis Division (800) 490-7707

Mississippi Division (800) 541-6709 * Nebraska Division (800) 801-0336