

SUBMITTAL RECORD \_\_\_\_\_  
 JOB \_\_\_\_\_  
 LOCATION \_\_\_\_\_  
 SUBMITTED TO \_\_\_\_\_  
 SUBMITTAL PREPARED BY \_\_\_\_\_  
 APPROVED BY \_\_\_\_\_  
 DATE \_\_\_\_\_

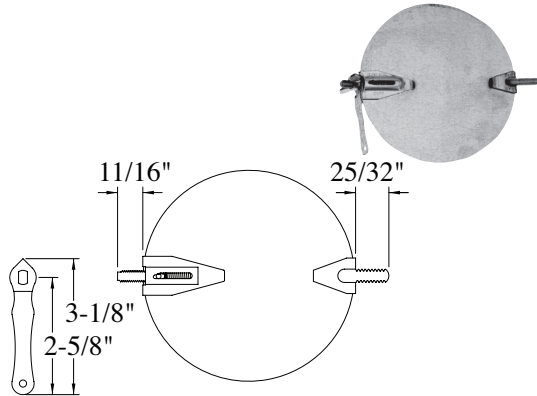

# Submittal Form JDS, JD, JDE, QJDE, HDJD Jiffy Dampers



The "JDS" Series Jiffy Damper offers the contractor a quality round damper at a cost lower than most shop-made dampers. The Duro Dyne JDS series utilizes quality Rapit Spring and Rapit Solid End Bearing sets.

Blade gauge is as follows: 4" thru 8" are 26ga galvanized steel and 9" & 14" are 24ga galvanized steel.

JDS JIFFY DAMPERS			
ITEM#	CODE	FOR DUCT SIZE DIA.	QTY
8092	JDS4	4"	10 Per Ctn
8093	JDS5	5"	10 Per Ctn
8094	JDS6	6"	10 Per Ctn
8095	JDS7	7"	10 Per Ctn
8096	JDS8	8"	10 Per Ctn
8097	JDS9	9"	10 Per Ctn
8137	JDS10	10"	10 Per Ctn
7188	JDS12	12"	10 Per Ctn
7189	JDS14	14"	10 Per Ctn
6335	JDS16	16"	10 Per Ctn

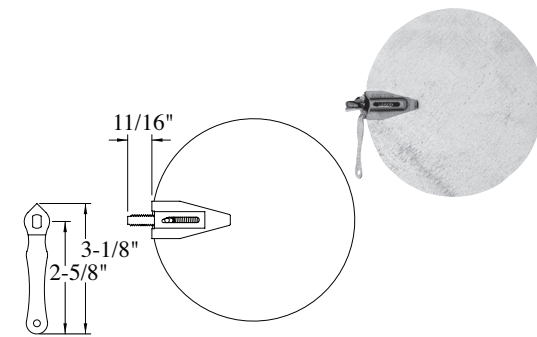

The "JD" Series Jiffy Damper offers added economy in those applications where a supporting solid tail bearing is not required on the damper. The Duro Dyne JD Damper utilizes one Rapit Spring End Bearing.

Blade gauge is as follows: 4" thru 8" are 26ga galvanized steel and 9" & 10" are 24ga galvanized steel.

JD JIFFY DAMPERS			
ITEM#	CODE	FOR DUCT SIZE DIA.	QTY
8098	JD4	4"	10 Per Ctn
8099	JD5	5"	10 Per Ctn
8100	JD6	6"	10 Per Ctn
8101	JD7	7"	10 Per Ctn
8146	JD8	8"	10 Per Ctn
8140	JD10	10"	10 Per Ctn

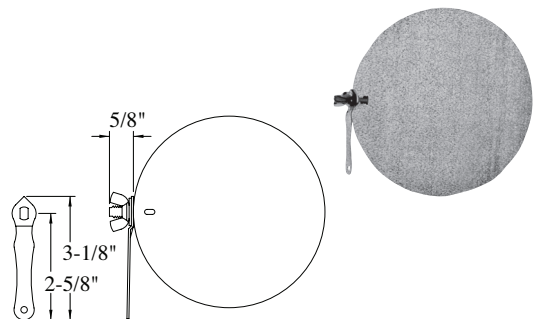

The "QJDE" Series Jiffy Damper offers an inexpensive alternative for low pressure applications. The Duro Dyne Economy Damper utilizes one threaded stud as a support bearing.

Blade gauge is as follows: 5" thru 8" are 26ga galvanized steel.

QJDE JIFFY DAMPERS			
ITEM#	CODE	FOR DUCT SIZE DIA.	QTY
6238	QJDE5H*	5"	100 Per Ctn
6239	QJDE5H*	6"	100 Per Ctn
6240	QJDE5H*	7"	100 Per Ctn
6241	QJDE5H*	8"	100 Per Ctn
6245	QJDE5HW**	6"	100 Per Ctn
6246	QJDE5HW**	7"	100 Per Ctn

\*Unattached

\*\*Bag attached

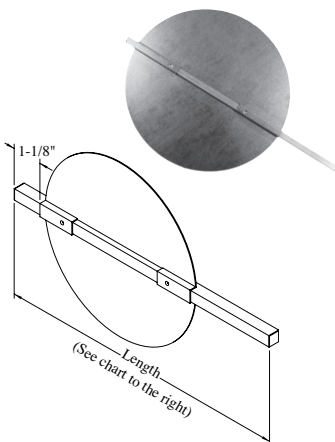

The Heavy Duty Jiffy Damper (HDJD) offers an economical alternative to in shop damper fabrication. It is manufactured of 22 gauge galvanized steel blades and comes pre-assembled. The 3/8" square rod extends 3 inches beyond the blade. 2 "dimples" hold the rod in place during assembly. The HDJD is compatible with Duro Dyne's ESO damper regulator assembly.

HEAVY DUTY JIFFY DAMPERS						
ASSEMBLED		UNASSEMBLED		FOR DUCT SIZE DIA.	QTY	LENGTH
ITEM#	CODE	ITEM#	CODE			
7077	HDJD4	6357	HDJD4UA	4"	10 Per Ctn	8"
7078	HDJD5	6358	HDJD5UA	5"	10 Per Ctn	9"
7163	HDJD6	6359	HDJD6UA	6"	10 Per Ctn	10"
7164	HDJD7	6360	HDJD7UA	7"	10 Per Ctn	11"
7165	HDJD8	6361	HDJD8UA	8"	10 Per Ctn	12"
7166	HDJD9	6362	HDJD9UA	9"	10 Per Ctn	13"
7167	HDJD10	6363	HDJD10UA	10"	10 Per Ctn	14"
7168	HDJD12	6364	HDJD12UA	12"	10 Per Ctn	16"
7169	HDJD14	6365	HDJD14UA	14"	10 Per Ctn	18"
7170	HDJD16	6366	HDJD16UA	16"	10 Per Ctn	20"
7273	HDJD18	.	.	18"	10 Per Ctn	22"
7274	HDJD20	.	.	20"	10 Per Ctn	24"
7275	HDJD22	.	.	22"	10 Per Ctn	26"
7276	HDJD24	.	.	24"	10 Per Ctn	28"

Duro Dyne Corporate Headquarters, Bay Shore, NY

631-249-9000 • Fax: 631-249-8346

Duro Dyne Midwest • Duro Dyne West • Duro Dyne Canada

www.durodyne.com • E-mail: durodyne@durodyne.com



©2021 Duro Dyne Corporation

Printed in USA 2/25/2021

BO008434