



**PARTS:**

1. CURTAIN TYPE, STAINLESS STEEL
2. UL LISTED FUSIBLE LINK (165°F STANDARD, 212°F OPTIONAL)
3. FRAME (20GA. GALVANIZED STEEL FOR DAMPERS ≤10" DIAMETER, 16GA. GALVANIZED STEEL FOR DAMPERS ≥11" DIAMETER)
4. LOCK ASSEMBLY
5. MAIN CURTAIN STAY

**FEATURES:**

MEETS ALL UL AND NFPA REQUIREMENTS FOR PRIMARY FIRE DAMPERS. APPROVED FOR USE WHERE DUCTS PENETRATE PARTITIONS WITH FIRE RESISTANCE RATINGS OF TWO HOURS OR LESS.

ONE PIECE STAINLESS STEEL CURTAIN FOR VERTICAL OR HORIZONTAL INSTALLATION.

1-1/2 HOUR RATING, FOR USE IN FIRE BARRIERS RATED FOR 2 HOURS OR LESS.

4" - 14" DIAMETER IN 1" INCREMENTS.

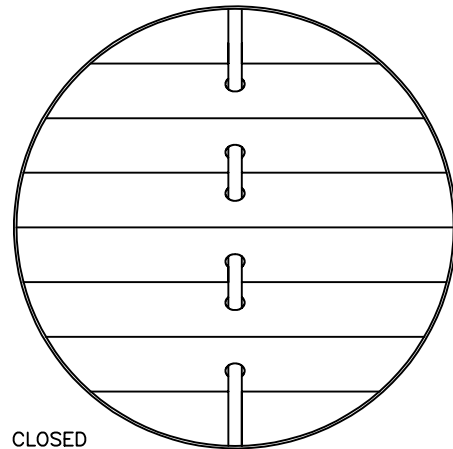
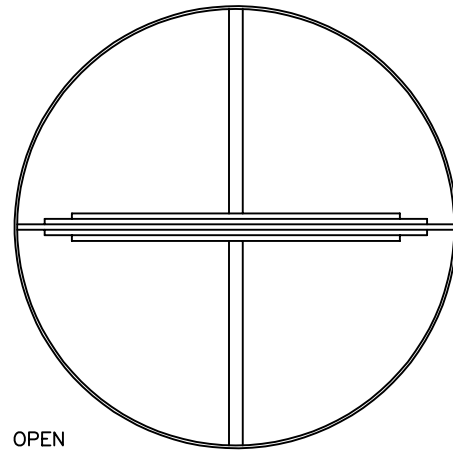
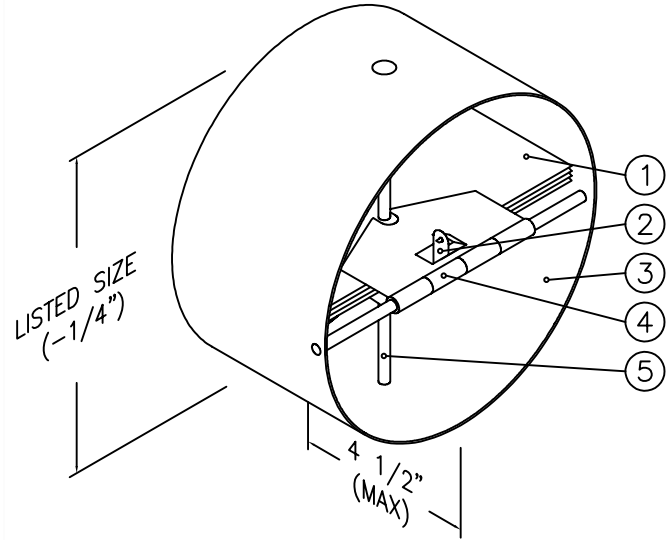

JOB NAME:
LOCATION:
ARCHITECT:
ENGINEER:
CONTRACTOR:
CONTACT MIAMI TECH INC. FOR ADDITIONAL INFORMATION OR WITH SPECIAL REQUIREMENTS.
3611 NW 74TH ST MIAMI, FL 33147 PHONE: 305-693-7054 FAX: 305-693-6152
WEB: WWW.MIAMITECH.COM EMAIL: SALES@MIAMITECH.COM

**US-3**

HORIZONTAL OR VERTICAL CURTAIN TYPE FIRE DAMPER  
1 1/2 HOURS, DYNAMICALLY RATED  
PRODUCT SPECIFICATIONS

NOTE: ALL DRAWINGS SUBJECT TO CHANGE WITHOUT PRIOR NOTICE.



DRAWN BY: AF	DATE: 11/12/07	SCALE: NOT TO SCALE	DRAWING NO. US-3
CHECKED BY: IG	DATE: 2/17/21	REVISION: 6	