

**Cable Shark Cable Hanging System
Construction Standards
Ductmate Industries**

Version 1.0
June 2021

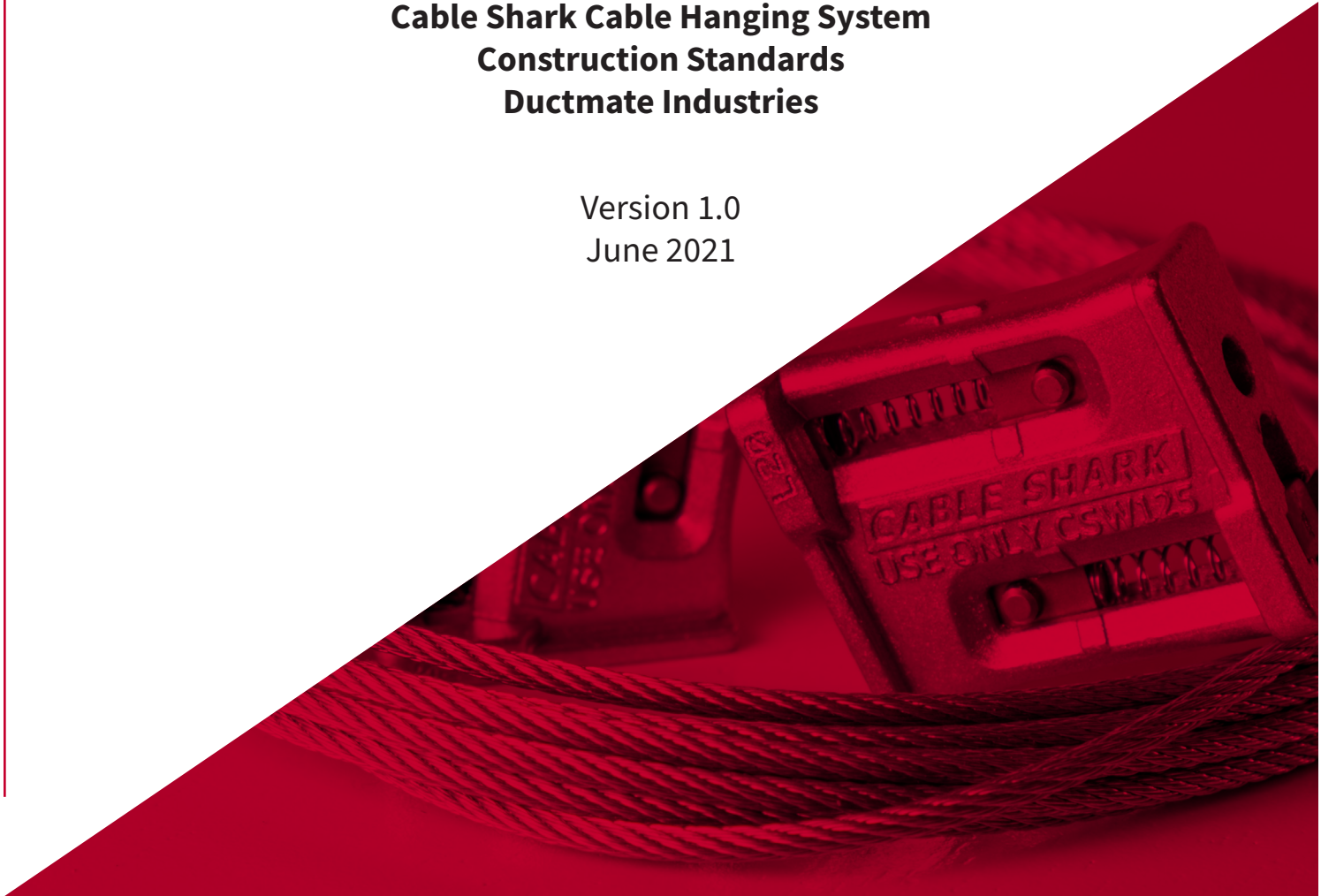

WARNING

CABLE

- Use ONLY Cable Shark Cable when using the Cable Shark System.
- Use ONLY the correct sized Cable Shark Cable, corresponding to the Cable Shark mechanism.
- ALWAYS INSPECT cable for WEAR, DAMAGE, or ABUSE BEFORE and DURING USE.
- NEVER USE cable that is DAMAGED or ABUSED.
- NEVER REUSE cable or mechanisms under ANY CIRCUMSTANCE.
- DESTROY and DISCARD used, worn out or damaged cable in a fashion that does not permit use by someone who does not know the hazard.
- Cable WILL FAIL if used, worn-out, overloaded, misused, damaged, improperly maintained or abused.
- DO NOT use beyond the appropriate factor of safety.
- ALL USERS should be informed of ALL cable and safety precautions.
- REFER TO all applicable codes, standards and regulations for inspection requirements and removal criteria.
- WHEN SELECTING an upper attachment consult SMACNA Duct Construction Standards, Hangers and Supports.
- CABLE FAILURE may cause serious injury or death.
- PROTECT yourself and others.

RESPONSIBILITY FOR PROPER AND SAFE USE OF THE CABLE RESTS WITH THE USER.



Please see Ductmate Cable Shark Specification Sheet for comprehensive specifications and instructions, as well as warnings and caution statements.

Table of Contents

Section 1 - Summary	2
Section 2 - Environmental and Load Considerations	2
Section 3 - Size Selection	2-3
Section 4 - Hanging Configurations Round	4-6
Section 5 - Hanging Configurations Rectangular	7
Section 6 - Hanging Configurations Oval	8
Section 7 - Duct Stability	9
Section 8 - Prohibited Configurations	10
Section 9 - Multiple Size Duct Sections	11
Section 10 - Attachment to the Structure	11-12
Section 11 - Construction Notes	12-13
Section 12 - Examples	14-16
Appendix A - Estimating the Hanging Angle on the Single Point Saddle Configuration	17-18
Appendix B - Estimating the Hanging Angle on the Spread Horseshoe Configuration	19-22
Appendix C - Round Duct Weight Estimation	23-25
Appendix D - Rectangular Duct Weight Estimation	26-29
Appendix E - Oval Duct Weight Estimation	30

1. Summary

These construction standards are intended to provide HVAC design engineers, architects, and contractors with the proper guidance needed to safely use Ductmate's Cable Shark Cable Hanging system.

Properly sized and spaced, the Ductmate Cable Shark Cable Hanging system provides a safe, cost effective hanging solution that is quick to install.

When selecting a HVAC duct hanging system there are multiple aspects to consider:

- Environmental and Load Considerations.
- Hanging Configuration.
- Size Selection.
- Attachment Method.
- When selecting an upper attachment consult SMACNA Duct Construction Standards, Hangers and Supports.

2. Environmental and Load Considerations

Ductmate's Cable Shark Cable Hanging system is designed for typical indoor environments and static loads.

The following conditions are not permitted:

- Corrosive environments, such as indoor swimming pool facilities or spa areas.
- Dynamic loads, such as suspension of pumps or compressors.

The Cable Shark Cable Hanging system must not be used for lifting objects. The system is specifically designed for supporting static loads such as HVAC ductwork.

3. Size Selection

Consider the following when selecting the correct size Cable Shark:

- Total weight of the duct (duct dimensions, metal gauge, single wall, double wall, fittings...)
- Hanger spacing.
- Hanging configuration.
- Cable angles.

The Ductmate Cable Shark Cable Hanging system is offered in two sizes.

Cable Shark	Cable
CS125	CSW125
CS250	CSW250

Experienced Sheet Metal Workers and Engineers will know how to calculate the total weight of the duct system segments and then properly select the appropriate hanging configuration, Cable Shark System size, and hanger spacing. The tables in Appendix C, D, and E are provided as a quick reference and alternative to the calculation.

Steps to properly select the correct size Cable Shark:

1. Determine the following for each size duct section in the system.
 - Type of duct.
 - Duct section dimensions.
 - Duct section weight.
 - Hanger spacing constraints.
 - Height between the duct section and suspension point.
2. Select the hanger spacing based upon available structure attachment points.
 - Typical hanger spacing is between 5 feet and 12 feet.
 - Less than 5 foot spacing can be difficult to install so that all hangers are carrying the proper load.
 - Greater than 12 foot spacing is not permitted by SMACNA.
3. Select an approved hanging configuration and Cable Shark System size that:
 - Best carries the duct section weight.
 - Conforms to the hanging limits specified for the selected configuration.
 - Provides the desired level of hanging stability.

4. Hanging Configurations (Round)

There are four approved hanging configurations for the Cable Shark Cable Hanging system for round duct:

A. Standard Horseshoe

- In this configuration the Cable Shark Cable is looped through the upper suspension point and secured with a Cable Shark (or ferrule loop) device, then routed under the ductwork and to a second suspension point to be secured with another Cable Shark device. It is also possible to use one continuous loop and one Cable Shark device as shown below. This method helps to eliminate some swinging in the ductwork. Using two Cable Shark devices on a single cable at separate attachment points does not change the maximum stated load rating.
- The maximum load capacity of the Cable Shark 125 in this configuration is 250 lbs. The maximum load capacity for the Cable Shark 250 in this configuration is 500 lbs.

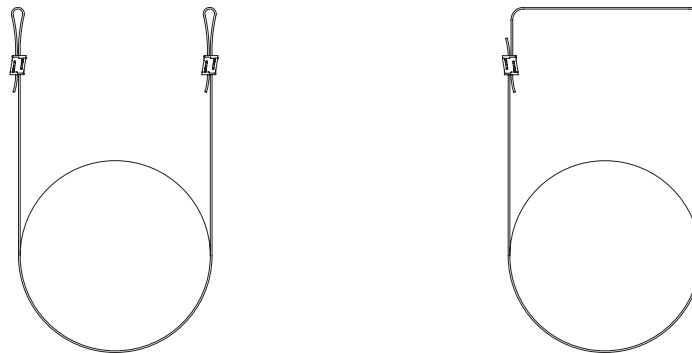

B. Spread Horseshoe

- This configuration has the same cable routing as the standard horseshoe, but the distance between the suspension points is greater than the width of duct being hung creating a measure of cross bracing. This configuration can be used when additional stability is desired. Items can be hung at angles up to 60 degrees from vertical.

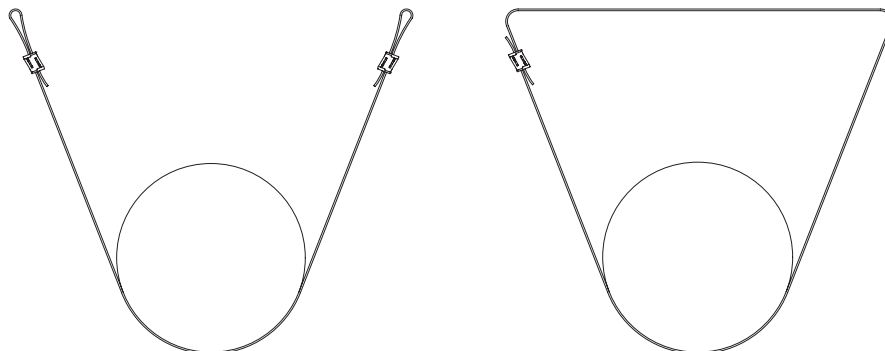

- Load limits for this configuration are dependent on the angle between the cable and the vertical axis. When using this table always round the angle up to the next larger angle listed. The maximum allowed angle is 60 degrees.

Table 1 - Spread Horse Shoe Suspension Limits

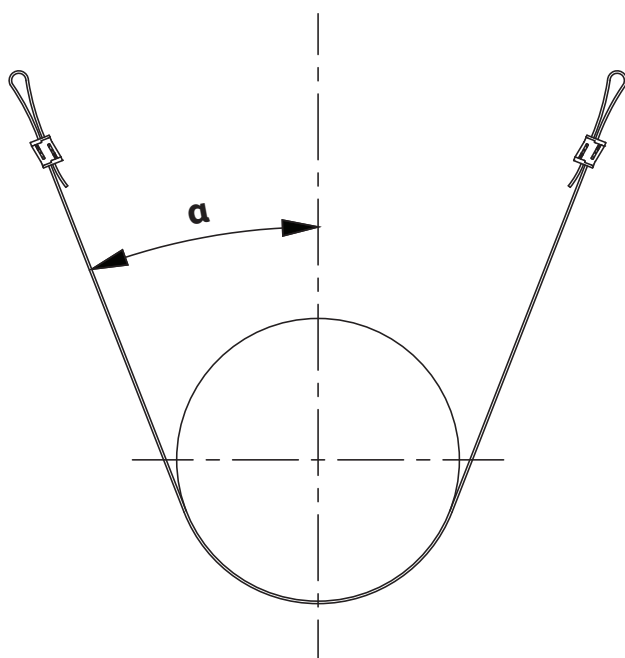

Angle	CS125 Max Load (lbs)	CS250 Max Load (lbs)
0°	250	500
5°	250	500
10°	250	500
15°	250	500
20°	250	500
25°	250	500
30°	250	480
35°	241	454
40°	226	425
45°	208	392
50°	189	356
55°	169	318
60°	147	277

Note these limitations are valid for dual suspension points regardless if one or two devices are used.

C. Single Point Saddle

- In this configuration the Cable Shark Cable is looped through an eye bolt or suitable suspension point, routed under the duct, and then secured to the same suspension point.

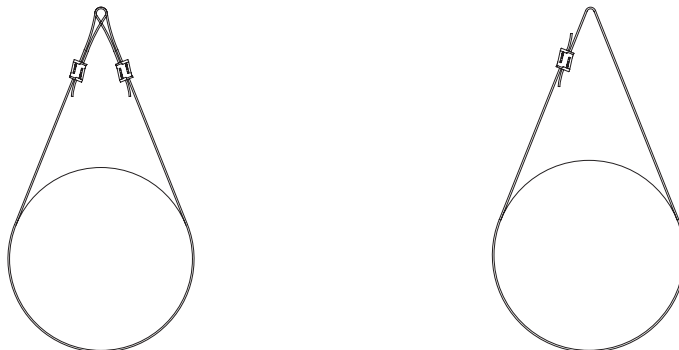

- Load limits for this configuration are dependent on the angle between the cable and the vertical axis. When using this table always round the angle up to the next larger angle listed. The maximum allowed angle is 60 degrees.

Table 2 - Single Point Saddle Suspension Limits

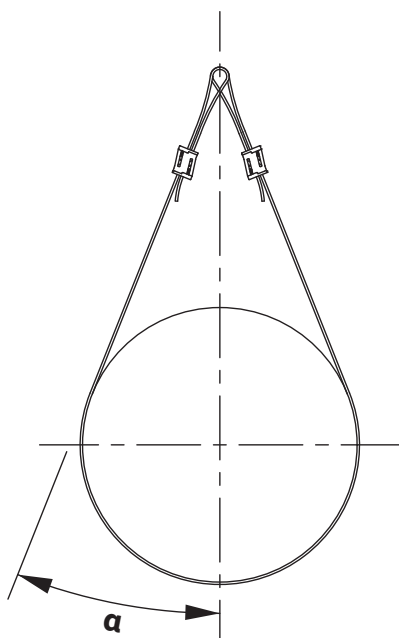

Angle	CS125 Max Load (lbs)	CS250 Max Load (lbs)
0°	250	500
5°	250	500
10°	250	500
15°	250	500
20°	250	500
25°	250	500
30°	250	480
35°	241	454
40°	226	425
45°	208	392
50°	189	356
55°	169	318
60°	147	277

Note these limitations are valid for dual suspension points regardless if one or two devices are used.

D. Standard Loop

- In this configuration the Cable Shark Cable is looped around the upper support and secured with a Cable Shark mechanism, then looped around the duct and secured with another Cable Shark mechanism. This configuration can be used for general purpose hanging and is suitable for applications where the duct will not experience lateral forces or be prone to swinging.

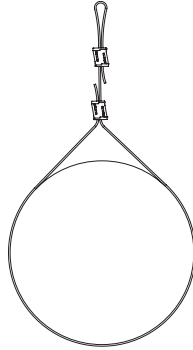

- The load limit of the standard loop configuration is limited by the duct diameter and the height above which the Cable Shark is placed. Follow these specified limitations.
 - The Cable Shark 250 in the standard loop configuration may be used on round ducts with diameters 18" (45.72 cm) or less without additional limitation.
 - The Cable Shark 125 in the standard loop configuration may be used on round ducts with diameters 10" (25.4 cm) or less without additional limitation.
 - The Cable Shark 250 and 125 may be used on larger diameter duct provided the device is placed $\frac{1}{2}$ the diameter of the duct above the duct and the duct section weight does not exceed the device maximum load limits of 250 lbs and 125 lbs respectively.
 - Consult Ductmate for hanging configuration options beyond what is specified here.

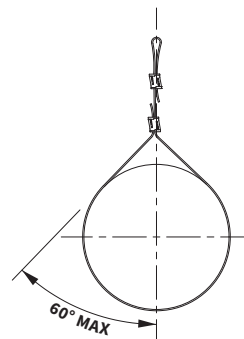
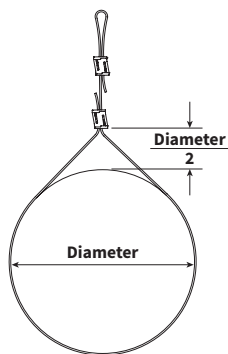

5. Hanging Configurations (Rectangular)

A. Spread Horseshoe

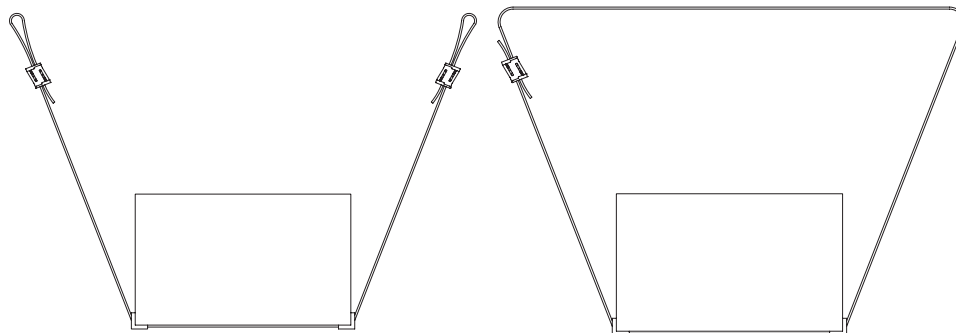

B. Standard Horseshoe

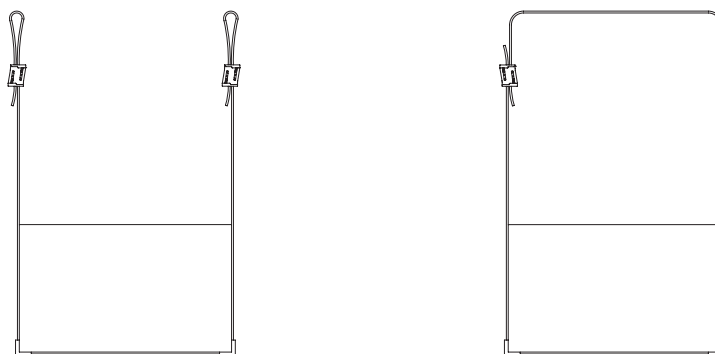

C. For rectangular duct it is necessary to insulate the Cable Shark Cable from the duct to eliminate abrasion. This is accomplished by using the Ductmate Rectangular Duct Corner Saddles, part number HFCCS.

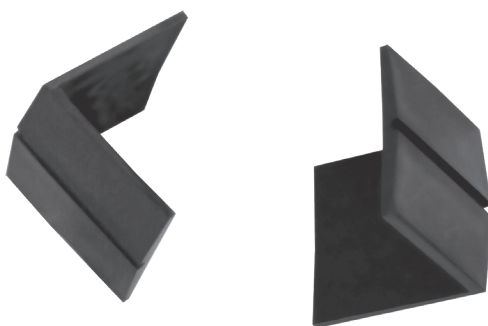

6. Hanging Configurations (Oval)

A. Spread Horseshoe

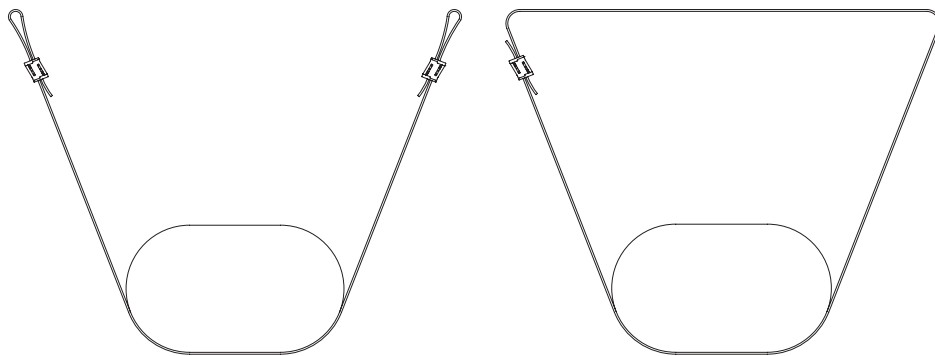

B. Standard Horseshoe

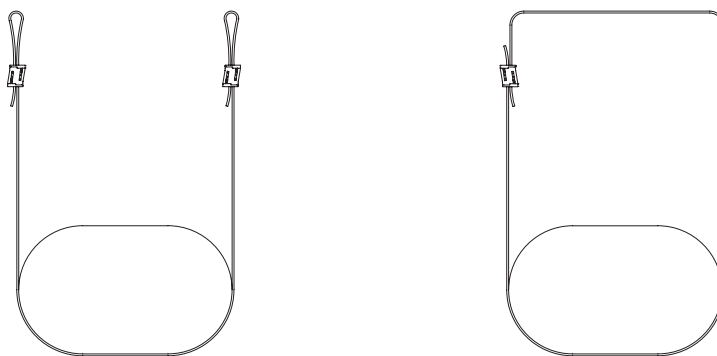

7. Duct Stability

Potential motion of the duct system must be considered when deciding on which type of hanging configuration to use. Repeated motion may cause ductwork to flex and could lead to fatigue failure.

Movement can be introduced into the system from sources such as:

- Air handler motion.
- Air exiting register grilles on one side of duct only.
- External impact forces.

The geometry of the duct system greatly affects the potential for motion. Long straight duct runs securely fixed at only one end are most likely to move. If unrestrained, the free end of the duct may oscillate. Most vertical hanging systems (including threaded rod and strapping) without lateral support will permit lateral motion and allow oscillation. If movement in the system is a concern, the Spread Horseshoe Hanging Configuration or supplemental lateral support must be used to reduce and constrain potential movement. See Table 3 for a cross-reference of hanging configuration and stability performance.

Table 3 - Hanging Configuration Stability Matrix

	Round Duct	Rectangular Duct	Oval Duct	Stability	Load Capacity
Spread Horseshoe	Allowed	Allowed	Allowed	Maximum	Good
Standard Horseshoe	Allowed	Allowed	Allowed	Good	Maximum
Single Point Saddle	Allowed	Prohibited	Prohibited	Minimum	Good
Standard Loop	Allowed	Prohibited	Prohibited	Minimum	Minimum

8. Prohibited Configurations

The following hanging configurations are prohibited.

No Ferrule Around Duct



Prohibited Beam Hanging Configurations - See Approved Beam Hanging Configuration in Section 10 on Page 11.

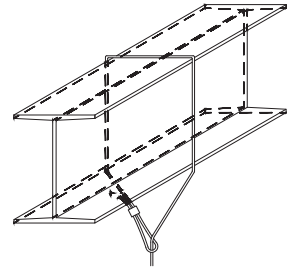
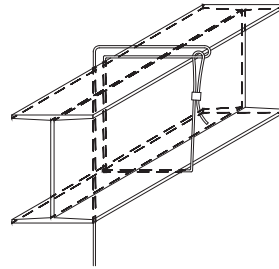
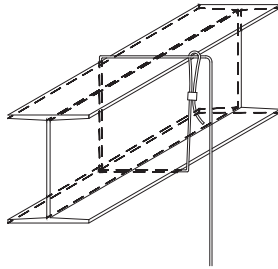
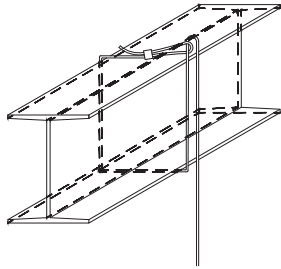

No Cable Shark as Anchor Point

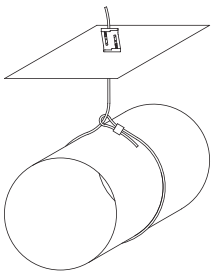

No Single Point on Rectangular Duct

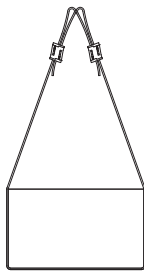

No Standard Loop on Rectangular Duct

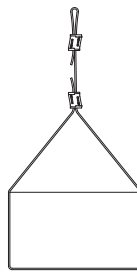

No Single Point on Oval Duct

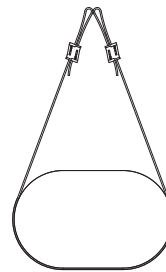

No Standard Loop on Oval Duct

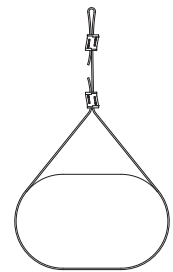

Splicing two or more lengths of Cable Shark Cable together with Cable Shark devices is prohibited.

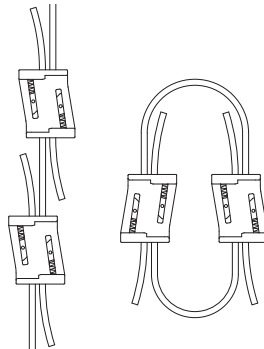

The Cable Shark Cable Hanging system derives some of its load carrying ability from the friction force created by wrapping the cable around the attachment point. Attempting to support a load by passing the Cable Shark Cable through only the locking bore of the Cable Shark device will result in a significantly lower holding capacity. The practice is strictly prohibited.

WARNING

Do not use the Cable Shark device to splice two cables together or to secure the Cable Shark Cable with only one bore of the Cable Shark Device.

9. Multiple Size Duct Sections

In systems with multiple size duct sections, size the hanger of each suspension point based on duct weight and hanging configuration. For the first hanger after a transition to a smaller size duct use the same size Cable Shark as the larger duct. Avoid using the Cable Shark 250 on light weight duct that is better suited for the Cable Shark 125.

Example: If a system has 56" diameter spiral duct that requires Cable Shark 250's and transitions to 48" diameter spiral duct that only requires Cable Shark 125's, the following can be done:

- Use Cable Shark 250's to suspend the 56" diameter duct at the prescribed spacing.
- The first hanger after the transition must also be a Cable Shark 250.
- All remaining Cable Sharks thereafter can be 125's at the prescribed spacing.

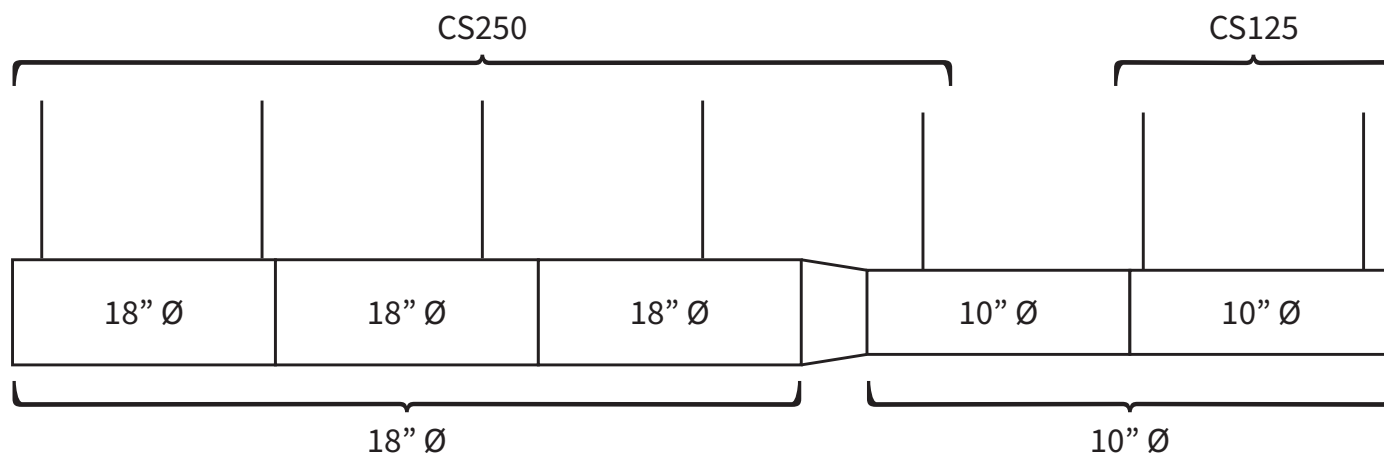

10. Attachment to the Structure

Selecting the appropriate connection between the structure and the Cable Shark Cable is critical. There are many ways to connect the cable to the structure, but it is the responsibility of the installer to ensure the structure and connecting hardware, if used, is rated to support the load.

Typical connection methods include:

- Looping the cable around a part of the structure, see image below for approved configuration.
- Using a connecting piece of hardware such as an eye bolt.

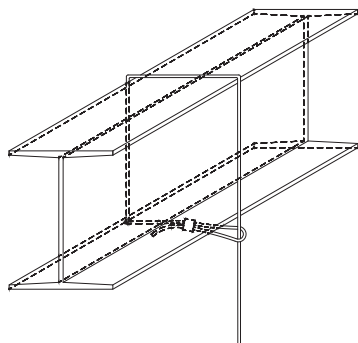

WARNING

Regardless of the application, the load carrying capacity of any cable is reduced by sharp edges and bending radii. Cable Shark Cable is not permitted to touch sharp edges because the edges can wear cable over time and reduce its load carrying capacity.

Avoid sharp bends in the Cable Shark Cable that substantially reduce its load carrying capacity.

A 3/16" radius or a diameter less than 3/8" is considered to be sharp. If an attachment with a sharp edge is being used, a cable thimble as shown to the right must be hooked through the eye of the attachment. The cable must be looped around the thimble to ensure the working load limits.



Examples of attachments that create a sharp edge include:

- Welded eye bolt 3/8" and smaller.
- Hole drilled into beam or purlin.
- Wood/concrete/steel anchors with eyelet.

11. Construction Notes

There are four approved hanging configurations for the Cable Shark Cable Hanging system for round duct:

- A. Using the Cable Shark. The following steps must be taken to maintain the static working load:
- Insert the cable through one of the two bores of the Cable Shark.
 - Pass the cable around an appropriate attachment device.
 - Secure the cable through the second bore of the Cable Shark.
 - Pull the cable taut and ensure the locking wedge has securely engaged the cable. An alignment mark is cast into the Cable Shark device to indicate when the wedge has securely engaged the cable.
 - Ensure there is at least 3" of cable protruding from the casting through the locking wedge.

WARNING

Once the Cable Shark Cable has been installed into the Cable Shark mechanism and the ductwork has been level, the wedge pins must be set past the load indicator mark, do not attempt to release the wedges. Once the wedges reach the load indicator mark, the wedges are designed to engage the Cable Shark Cable to properly grip the Cable Shark Hanging system in place. If the wedge pins have not been engaged, the device can be re-adjusted to level the system. Cable Shark Hanging system is designed for single use only. If the Cable Shark Hanging system needs to be removed, replace with all new components and do not reuse any used components.

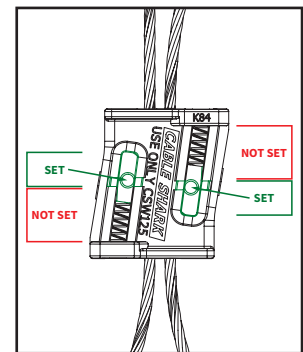
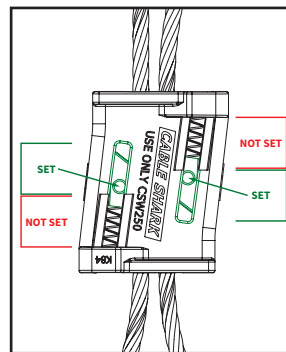

B. Paints and Lubricants

- Foreign products such as paints and lubricants may have adverse effects on the performance of the Cable Shark Cable Hanging system. Paints and Lubricants must not be applied to the Cable Shark device or the Cable Shark Cable.
- The Cable Shark paint cover should be used if the Cable Shark or Cable Shark Cable are likely to be painted. Properly installed, the paint cover will keep paint out of the locking mechanism.

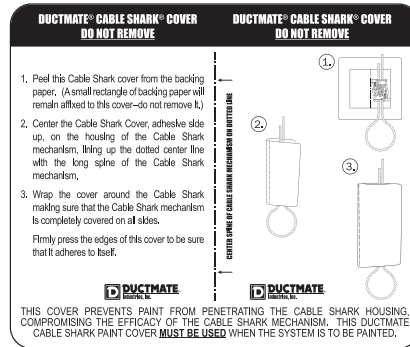

- C. Cable Cutting. To ensure that a clean cut is made every time on Cable Shark Cable, be sure to use Ductmate's steel cable cutters or other commercially available cable cutter.



Ductmate Light Duty Steel Cable Cutter (HFWRC)

- D. Tensioning Tool. To ensure the Cable Shark wedges are properly set, be sure to use Ductmate's tensioning tool.



Ductmate Tensioning Tool (HFTTM)

12. Examples

A 132' span of single wall spiral duct consists of 4 different duct diameters shown below (neglect reducer length). All of the duct sections are made from 22 gage galvanized steel and each section is 12' long. There are beams located above the duct spaced every 10'. There is 12" of clearance between the 54" duct and the beams. The beams run perpendicular to the duct along its entire span and do not have sharp edges. Registers are spaced evenly on both sides of the duct and the duct will not be exposed to corrosive materials or dynamic loading.

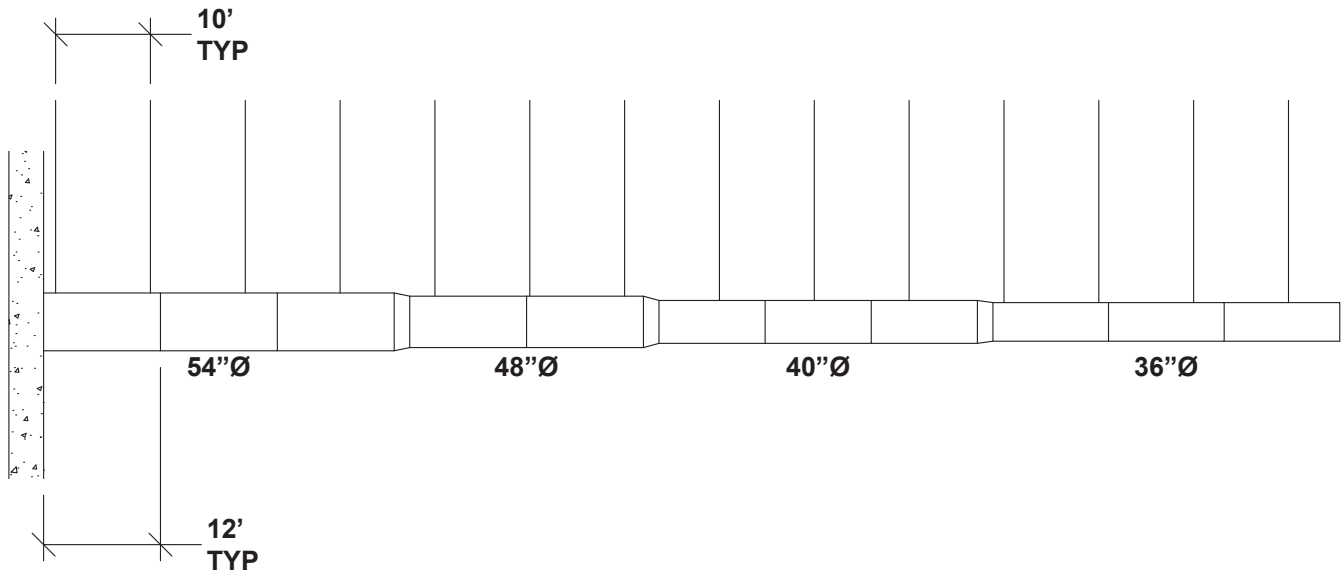

1. Which hanging configuration and Cable Shark best meets our design for the 54" section?

In this example, a 10' section of 54" diameter duct will weigh approximately 223 lbs. The standard horseshoe method is the best hanging configuration because it can support the most weight. The Cable Shark 125 in the standard horseshoe configuration can support up to 250 lbs and Cable Shark 250 can support up to 500 lbs. Therefore, the Cable Shark 125 in the horseshoe configuration is best.

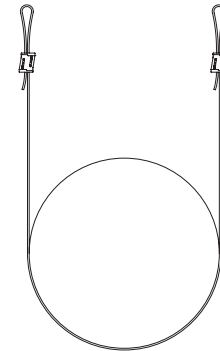

2. Which hanging configurations could also be used on the 54" section?

The spread horseshoe or single point saddle method could also be used depending on the hanging angles and published load limits.

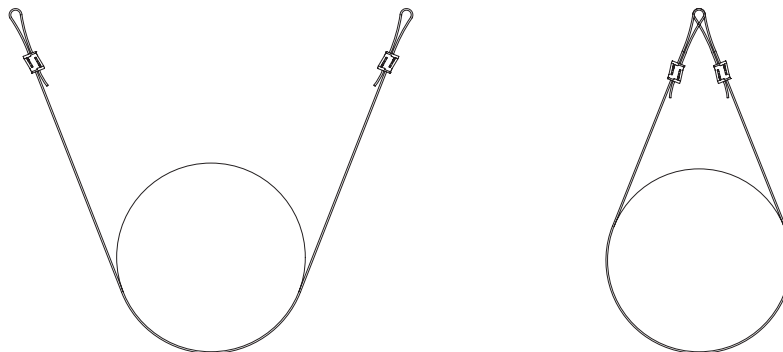

To determine the angle for the spread horseshoe configuration, use Table B1 Spread Horseshoe Angles (10" Height). This table shows the suspension points can range between 60" (5 degrees) and 170" (50 degrees) apart without exceeding the maximum 60-degrees from vertical. After the hanging angles are determined it is necessary to determine the load carrying capacity of the hanging device at these angles as summarized below. In this example the load capacity of the Cable Shark 125 is exceeded at 50 degrees so it is necessary to look up in the Spread Horseshoe Load Table the angle which the Cable Shark 125 can carry 223 lbs. In this example it can carry 241 lbs when the hanging angle is less than 35 degrees.

Table 4 - Load Capacity Summary for Example Problem

	Angle	Spacing [in]	Load Capacity [lbs]
Cable Shark 125	5°	60	250
Cable Shark 125	50°	170	189*
Cable Shark 125	35°	110	241
Cable Shark 250	5°	60	500
Cable Shark 250	50°	170	356

* This configuration does not work because the Cable Shark 125 can only carry 189 lbs when the duct is 12" from the ceiling and the suspension points are 170" apart.

To determine the angle for the single point saddle configuration, use Table A1 Single Point Saddle Angles. This table shows that a 54" diameter duct hung 12" below the suspension point will have an angle of 44 degrees which is less than 60 degrees. At this angle the Cable Shark 125 can only carry 208 lbs so it cannot be used and the Cable Shark 250 can carry 392 lbs according to Table 2.

3. Which hanging configurations cannot be used on the 54" section?

The standard loop configuration may not be used on the 54" duct because the duct diameter is in excess of 18" (for Cable Shark 250) and the minimum required height above the duct for the Cable Shark device is 27" ($54" / 2$). Since there is only 12" of space between the duct and beam this method is not allowed.

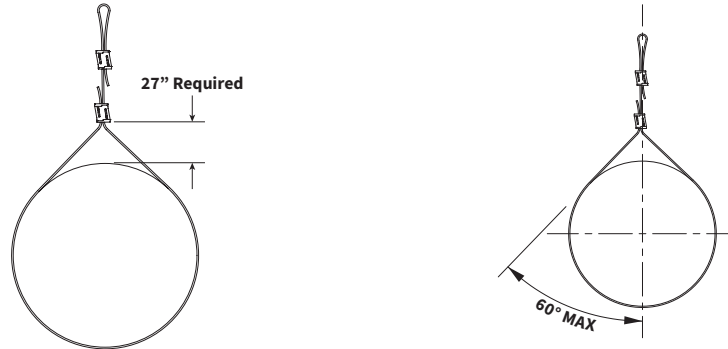

4. What are the load limits of the Cable Shark 250 for each configuration?

Standard Horseshoe configuration: 500 lbs

Spread Horseshoe configuration (5 degrees): 500 lbs

Spread Horseshoe configuration (50 degrees): 356 lbs

Single Point Saddle configuration (44 degrees): 392 lbs

5. What are the load limits of the Cable Shark 125 for each configuration?

Standard Horseshoe configuration: 250 lbs

Spread Horseshoe configuration (5 degrees): 250 lbs

Spread Horseshoe configuration (35 degrees): 241 lbs

Single Point Saddle configuration (44 degrees): 208 lbs which is insufficient for this application.

Appendix A. Estimating the Hanging Angle on the Single Point Saddle Configuration

Round Duct. To determine angle between the Cable Shark Cable and the vertical axis using the single point saddle configuration you must know the round duct diameter and vertical distance (height) between the duct and the suspension point. See the figure below. Given these dimensions, use Table A1 to find the intersection of these values and read the angle value.

Interpolation rules.

1. When selecting a height not listed in the table, use the next smaller height. i.e., the next smaller height for 23" is 20".
2. When selecting a diameter not listed in the table, use the next larger diameter. i.e., the next larger diameter for 15" is 16". Note this rule is opposite of the spread horseshoe configuration diameter interpolation rule.

Example 1. A round duct with a diameter of 22" is 28" below the suspension point. Read across Table A1 on the 22" row until reaching the 28" column. The angle value is 16 degrees.

Example 2. A round duct with a diameter of 22" is 30" below the suspension point. In this case there is no 30" column so the next smaller height must be used. Read across Table A1 on the 22" row until reaching the 28" column. The angle value is 16 degrees.

Example 3. A round duct with a diameter of 21" is 28" below the suspension point. In this case there is no 21" diameter row so the next larger diameter must be used. Read across Table A1 on the 22" row until reaching the 28" column. The angle value is 16 degrees.

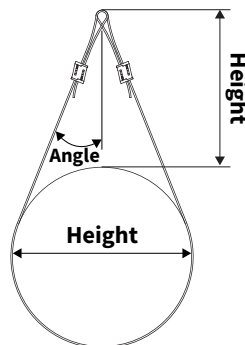
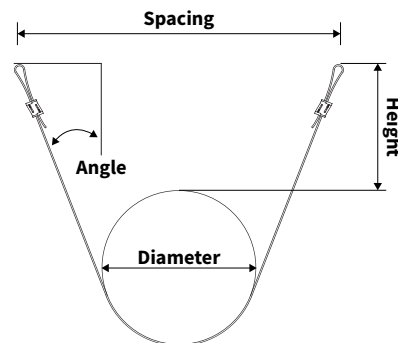

Table A1 - Single Point Saddle Angles

Diameter [in]	Height [in]													
	4	8	12	16	20	24	28	32	36	40	44	48	52	56
10	34	23	17	14	12	10	9	8	7	6	6	5	5	5
12	37	25	19	16	13	12	10	9	8	7	7	6	6	6
14	40	28	22	18	15	13	12	10	9	9	8	7	7	6
16	42	30	24	19	17	14	13	12	10	10	9	8	8	7
18	44	32	25	21	18	16	14	13	12	11	10	9	8	8
20	46	34	27	23	19	17	15	14	13	12	11	10	9	9
22	47	35	29	24	21	18	16	15	14	12	12	11	10	9
24	49	37	30	25	22	19	17	16	14	13	12	12	11	10
26	50	38	31	27	23	21	18	17	15	14	13	12	12	11
28	51	40	33	28	24	22	19	18	16	15	14	13	12	12
30	52	41	34	29	25	23	20	19	17	16	15	14	13	12
32	53	42	35	30	26	24	21	19	18	17	15	14	14	13
34	54	43	36	31	27	24	22	20	19	17	16	15	14	13
36	55	44	37	32	28	25	23	21	19	18	17	16	15	14
38	56	45	38	33	29	26	24	22	20	19	18	16	16	15
40	56	46	39	34	30	27	25	23	21	19	18	17	16	15
42	57	46	40	35	31	28	25	23	22	20	19	18	17	16
44	58	47	40	35	32	29	26	24	22	21	19	18	17	16
46	58	48	41	36	32	29	27	25	23	21	20	19	18	17
48	59	49	42	37	33	30	27	25	24	22	21	19	18	17
50	60	49	43	38	34	31	28	26	24	23	21	20	19	18
52		50	43	38	34	31	29	27	25	23	22	21	19	18
54		50	44	39	35	32	29	27	25	24	22	21	20	19
56		51	44	40	36	33	30	28	26	24	23	22	20	19
58		52	45	40	36	33	31	28	26	25	23	22	21	20
60		52	46	41	37	34	31	29	27	25	24	23	21	20
62		53	46	41	37	34	32	29	28	26	24	23	22	21
64		53	47	42	38	35	32	30	28	26	25	24	22	21
66		54	47	42	39	35	33	31	29	27	25	24	23	22
68		54	48	43	39	36	33	31	29	27	26	24	23	22
70		54	48	43	40	36	34	31	30	28	26	25	24	23

Appendix B. Estimating the Hanging Angle on the Spread Horseshoe Configuration

Round Duct. To determine the angle between the Cable Shark Cable and the vertical axis using the spread horseshoe configuration you must know the round duct diameter, vertical distance (height) between the duct and the suspension points, and the spacing between the suspension points. See the figure below. Given these dimensions, first locate the correct table for the height between the duct and suspension points. Then locate the intersection of the diameter and height dimensions to determine the angle value.



Spread Horseshoe Configuration Geometry

Interpolation rules.

1. When there is no table for the specific height, use the table with the next smaller height. i.e., the next smaller height table for 39" is 30".
2. When the suspension distance is not listed in the table, use the next larger suspension point spacing. i.e., the next larger suspension point spacing for 51" is 60".
3. When selecting a diameter not listed in the table, use the next smaller diameter. i.e., the next smaller diameter for 21" is 18". Note this rule is opposite of the single point saddle configuration diameter interpolation rule.

Example 1. A round duct with a diameter of 22" is 40" below the suspension points. The suspension points are 80" apart. First locate the table with the 40" height (Table B4). Read across the table on the 22" row until reaching the 80" column. The angle value is 28 degrees.

Example 2. A round duct with a diameter of 22" is 34" below the suspension points. The suspension points are 80" apart. In this case there is no table where the height is 34" so the next smaller height table must be used. Locate the table with the 30" height (Table B3). Read across the table on the 22" row until reaching the 80" column. The angle value is 33 degrees.

Example 3. A round duct with a diameter of 22" is 40" below the suspension points. The suspension points are 85" apart. First locate the table with the 40" height (Table B4). Since there is no column for 85" spacing, use the next larger spacing value. In this case the next larger spacing is 90". Read across the table on the 22" row until reaching the 90" column. The angle value is 32 degrees.

Example 4. A round duct with a diameter of 21" is 40" below the suspension points. The suspension points are 80" apart. First locate the table with the 40" height (Table B4). Since there is no row for 21" diameter duct, use the next smaller diameter value. In this case the next smaller diameter is 18". Read across the table on the 18" row until reaching the 80" column. The angle value is 31 degrees.

Table B1 - Spread Horseshoe Angles (10" Height)

Diameter [in]	Spacing [in]													
	40	50	60	70	80	90	100	110	120	130	140	150	160	170
10	42	49	55	59										
14	34	42	49	54	58									
18	27	36	43	48	53	56	60							
22	21	30	38	43	48	52	56	58						
26	16	25	32	39	44	48	52	55	57	60				
30	11	20	28	34	39	44	48	51	54	57	59			
34	6	15	23	30	35	40	44	48	51	53	56	58	60	
38	2	11	19	26	31	36	41	44	48	50	53	55	57	59
42		7	15	22	28	33	37	41	45	48	50	53	55	57
46		3	11	18	24	29	34	38	42	45	47	50	52	54
50			8	15	21	26	31	35	39	42	45	47	50	52
54			5	11	18	23	28	32	36	39	42	45	47	50
58				8	14	20	25	29	33	37	40	42	45	47
62				5	12	17	22	26	30	34	37	40	43	45
66					9	14	19	24	28	31	35	38	40	43
70					6	12	17	21	25	29	32	35	38	41
74						9	14	19	23	27	30	33	36	39
78						7	12	16	21	24	28	31	34	37
82							9	14	18	22	26	29	32	35

Table B2 - Spread Horseshoe Angles (20" Height)

Diameter [in]	Spacing [in]													
	40	50	60	70	80	90	100	110	120	130	140	150	160	170
10	30	37	43	48	52	55	58							
14	25	32	38	43	48	51	55	57	60					
18	20	27	34	39	44	48	51	54	56	59				
22	15	23	29	35	40	44	47	51	53	56	58	60		
26	12	19	25	31	36	40	44	47	50	53	55	57	59	
30	8	15	22	27	32	37	41	44	47	50	52	55	56	58
34	5	12	18	24	29	34	38	41	44	47	50	52	54	56
38		8	15	21	26	30	35	38	42	45	47	50	52	54
42		5	12	18	23	27	32	35	39	42	45	47	49	51
46			9	15	20	25	29	33	36	39	42	45	47	49
50			6	12	17	22	26	30	34	37	40	42	45	47
54			4	9	14	19	24	28	31	34	37	40	43	45
58				7	12	17	21	25	29	32	35	38	41	43
62				4	10	14	19	23	26	30	33	36	38	41
66					7	12	16	20	24	28	31	34	36	39
70					5	10	14	18	22	25	29	32	34	37
74						8	12	16	20	23	27	30	32	35
78						6	10	14	18	21	25	28	30	33
82							8	12	16	19	23	26	29	31

Table B3 - Spread Horseshoe Angles (30" Height)

Diameter [in]	Spacing [in]													
	40	50	60	70	80	90	100	110	120	130	140	150	160	170
10	23	29	34	39	43	47	50	53	56	58	60			
14	19	25	31	36	40	44	47	50	53	55	57	59		
18	15	21	27	32	36	40	44	47	50	52	54	56	58	60
22	12	18	24	29	33	37	41	44	47	50	52	54	56	58
26	9	15	21	26	30	34	38	41	44	47	49	52	54	55
30	6	12	18	23	27	31	35	39	42	44	47	49	51	53
34	4	9	15	20	24	29	32	36	39	42	44	47	49	51
38		7	12	17	22	26	30	33	37	39	42	45	47	49
42		4	10	15	19	23	27	31	34	37	40	42	45	47
46			7	12	17	21	25	29	32	35	38	40	43	45
50			5	10	14	19	23	26	30	33	36	38	41	43
54			3	8	12	16	20	24	27	31	33	36	39	41
58				6	10	14	18	22	25	28	31	34	37	39
62				4	8	12	16	20	23	26	29	32	35	37
66					6	10	14	18	21	25	28	30	33	35
70					4	8	12	16	19	23	26	28	31	34
74						7	10	14	18	21	24	27	29	32
78						5	9	12	16	19	22	25	28	30
82							7	11	14	17	20	23	26	28

Table B4 - Spread Horseshoe Angles (40" Height)

Diameter [in]	Spacing [in]													
	40	50	60	70	80	90	100	110	120	130	140	150	160	170
10	18	23	28	33	37	40	44	47	49	52	54	56	58	59
14	15	20	25	30	34	38	41	44	47	49	51	53	55	57
18	12	18	22	27	31	35	38	41	44	47	49	51	53	55
22	10	15	20	24	28	32	36	39	42	44	47	49	51	53
26	7	12	17	22	26	30	33	36	39	42	44	47	49	51
30	5	10	15	19	23	27	31	34	37	40	42	44	47	49
34	3	8	12	17	21	25	28	32	35	37	40	42	45	47
38		6	10	15	19	22	26	29	32	35	38	40	43	45
42		4	8	12	17	20	24	27	30	33	36	38	41	43
46			6	10	14	18	22	25	28	31	34	36	39	41
50			4	9	12	16	20	23	26	29	32	34	37	39
54			3	7	11	14	18	21	24	27	30	33	35	37
58				5	9	12	16	19	23	25	28	31	33	36
62				3	7	11	14	18	21	24	26	29	32	34
66					5	9	13	16	19	22	25	27	30	32
70					4	7	11	14	17	20	23	26	28	31
74						6	9	13	16	19	21	24	27	29
78						4	8	11	14	17	20	23	25	27
82							6	9	13	15	18	21	24	26

Table B5 - Spread Horseshoe Angles (50" Height)

Diameter [in]	Spacing [in]													
	40	50	60	70	80	90	100	110	120	130	140	150	160	170
10	15	20	24	28	32	35	38	41	44	46	49	51	53	54
14	13	17	22	26	29	33	36	39	42	44	46	49	50	52
18	10	15	19	23	27	30	34	37	39	42	44	46	48	50
22	8	13	17	21	25	28	31	34	37	40	42	44	46	48
26	6	11	15	19	22	26	29	32	35	38	40	42	44	46
30	4	9	13	17	20	24	27	30	33	36	38	40	43	45
34	3	7	11	15	18	22	25	28	31	34	36	38	41	43
38		5	9	13	16	20	23	26	29	32	34	37	39	41
42		3	7	11	14	18	21	24	27	30	32	35	37	39
46			5	9	13	16	19	22	25	28	31	33	35	37
50			4	7	11	14	18	21	24	26	29	31	34	36
54			2	6	9	13	16	19	22	25	27	30	32	34
58				4	8	11	14	17	20	23	26	28	30	33
62				3	6	10	13	16	19	21	24	26	29	31
66					5	8	11	14	17	20	22	25	27	30
70					3	7	10	13	16	18	21	23	26	28
74						5	8	11	14	17	19	22	24	27
78						4	7	10	13	15	18	21	23	25
82							6	8	11	14	17	19	22	24

Rectangular and Oval Duct. Consult an engineer to determine the hanging angle between the cable and vertical axis when used with rectangular or oval duct. The possible geometry combinations of rectangular and oval duct make it impractical to provide tabular data.

Appendix C. Round Duct Weight Estimation

The following tables provide a method to estimate the weight of a round spiral duct per linear foot. First find the table for the appropriate material, galvanized steel, stainless steel, or aluminum. Find the duct diameter in the diameter column. If the diameter falls between two numbers, use the next higher number. Read across the table to the appropriate material gauge and find the estimated weight in lbs per foot.

These tables include a 15% increase over the theoretical weight to allow for manufacturing variation and simple connectors. Large fittings such as elbows or Tee connectors will require the use of additional hangers. These tables do not include an allowance for additional environmental loads.

Example. Find the weight of a 10' section of 32" diameter, 26GA galvanized duct. Find the galvanized table and find 32. Read across the table to the 26GA column and find that the duct should weigh 7.5 lbs per foot. The weight of the duct is calculated by multiplying the length times the weight per foot; 10 x 7.5. The 10' duct section should approximately weigh 75 lbs.

Table C1 - Round Duct Lbs per Foot, Single Wall No Insulation (Galvanized Steel)

Diameter	28 GA	26 GA	24 GA	22 GA
6	1.4	1.6	2.0	2.5
8	1.8	2.1	2.7	3.3
10	2.3	2.7	3.4	4.1
12	2.8	3.2	4.1	5.0
14	3.2	3.7	4.7	5.8
16	3.7	4.3	5.4	6.6
18	4.1	4.8	6.1	7.4
20	4.6	5.3	6.8	8.3
22	5.1	5.9	7.5	9.1
24	5.5	6.4	8.1	9.9
26	6.0	6.9	8.8	10.7
28	6.4	7.5	9.5	11.6
30	6.9	8.0	10.2	12.4
32	7.3	8.5	10.8	13.2
34	7.8	9.1	11.5	14.0
36	8.3	9.6	12.2	14.9
38	8.7	10.1	12.9	15.7
40	9.2	10.7	13.6	16.5
42	9.6	11.2	14.2	17.3
44	10.1	11.7	14.9	18.2
46	10.6	12.3	15.6	19.0
48	11.0	12.8	16.3	19.8
50	11.5	13.3	16.9	20.6
52	11.9	13.9	17.6	21.5
54	12.4	14.4	18.3	22.3
56	12.9	14.9	19.0	23.1
58	13.3	15.5	19.7	23.9
60	13.8	16.0	20.3	24.8

Table C2 - Round Duct Lbs per Foot, Single Wall No Insulation (Stainless Steel)

Diameter	28 GA	26 GA	24 GA	22 GA
6	1.4	1.6	2.1	2.5
8	1.9	2.2	2.8	3.4
10	2.4	2.7	3.5	4.2
12	2.8	3.3	4.2	5.1
14	3.3	3.8	4.9	5.9
16	3.8	4.4	5.6	6.8
18	4.3	4.9	6.3	7.6
20	4.7	5.5	7.0	8.5
22	5.2	6.0	7.7	9.3
24	5.7	6.6	8.4	10.2
26	6.1	7.1	9.1	11.0
28	6.6	7.7	9.8	11.9
30	7.1	8.2	10.5	12.7
32	7.6	8.8	11.2	13.6
34	8.0	9.3	11.9	14.4
36	8.5	9.9	12.6	15.3
38	9.0	10.4	13.3	16.1
40	9.5	11.0	14.0	17.0
42	9.9	11.5	14.7	17.8
44	10.4	12.1	15.4	18.7
46	10.9	12.6	16.1	19.5
48	11.3	13.2	16.7	20.4
50	11.8	13.7	17.4	21.2
52	12.3	14.3	18.1	22.1
54	12.8	14.8	18.8	22.9
56	13.2	15.4	19.5	23.8
58	13.7	15.9	20.2	24.6
60	14.2	16.5	20.9	25.5

Table C3 - Round Duct Lbs per Foot, Single Wall No Insulation (Aluminum)

Diameter	28 GA	26 GA	24 GA	22 GA
6	0.5	0.6	0.7	0.9
8	0.6	0.7	0.9	1.2
10	0.8	0.9	1.2	1.4
12	1.0	1.1	1.4	1.7
14	1.1	1.3	1.7	2.0
16	1.3	1.5	1.9	2.3
18	1.4	1.7	2.1	2.6
20	1.6	1.9	2.4	2.9
22	1.8	2.0	2.6	3.2
24	1.9	2.2	2.8	3.5
26	2.1	2.4	3.1	3.7
28	2.2	2.6	3.3	4.0
30	2.4	2.8	3.6	4.3
32	2.6	3.0	3.8	4.6
34	2.7	3.2	4.0	4.9
36	2.9	3.4	4.3	5.2
38	3.0	3.5	4.5	5.5
40	3.2	3.7	4.7	5.8
42	3.4	3.9	5.0	6.1
44	3.5	4.1	5.2	6.3
46	3.7	4.3	5.4	6.6
48	3.9	4.5	5.7	6.9
50	4.0	4.7	5.9	7.2
52	4.2	4.8	6.2	7.5
54	4.3	5.0	6.4	7.8
56	4.5	5.2	6.6	8.1
58	4.7	5.4	6.9	8.4
60	4.8	5.6	7.1	8.7

Appendix D. Rectangular Duct Weight Estimation

The following tables provide a method to estimate the weight of a rectangular duct per linear foot. First find the table for the appropriate material, galvanized steel, stainless steel, aluminum. Then add the width and height of the rectangular duct and find that number in the “height + width” column. If the width plus height falls between two numbers, use the next higher number. Lastly read across the table to the appropriate material gauge and find the estimated weight per foot.

These tables include a 15% increase over the theoretical weight to allow for manufacturing variation and simple connectors. Large fittings such as elbows or Tee connectors will require the use of additional hangers. These tables do not include an allowance for additional environmental loads.

Example. Find the weight of a 10' section of 50" x 24" 24GA galvanized duct. Find the galvanized table and add 50 and 24 which is 74. Since 74 is not in the table use 76. Read across the table to the 24GA column and find that the duct should weigh 14.3 lbs per foot. The weight of the duct is calculated by multiplying the length times the weight per foot; 10×14.3 . The 10' duct section should approximately weigh 143 lbs.

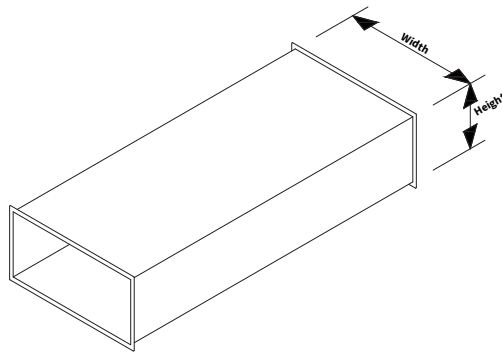

Table D1 - Rectangular Duct Lbs per Foot, No Insulation (Galvanized Steel)

Height + Width [in]	26 GA	24 GA	22 GA	20 GA	18 GA	16 GA
20	3.4	4.3	5.3	8.1	8.1	9.9
24	4.1	5.2	6.3	9.7	9.7	11.9
28	4.8	6.0	7.4	11.3	11.3	13.9
32	5.4	6.9	8.4	12.9	12.9	15.9
36	6.1	7.8	9.5	14.5	14.5	17.9
40	6.8	8.6	10.5	16.1	16.1	19.9
44	7.5	9.5	11.6	17.8	17.8	21.8
48	8.1	10.4	12.6	19.4	19.4	23.8
52	8.8	11.2	13.7	21.0	21.0	25.8
56	9.5	12.1	14.7	22.6	22.6	27.8
60	10.2	12.9	15.8	24.2	24.2	29.8
64	10.9	13.8	16.8	25.8	25.8	31.8
68	11.5	14.7	17.9	27.4	27.4	33.8
72	12.2	15.5	18.9	29.0	29.0	35.7
76	12.9	16.4	20.0	30.7	30.7	37.7
80	13.6	17.3	21.0	32.3	32.3	39.7
84	14.3	18.1	22.1	33.9	33.9	41.7
88	14.9	19.0	23.1	35.5	35.5	43.7
92	15.6	19.9	24.2	37.1	37.1	45.7
96	16.3	20.7	25.2	38.7	38.7	47.7
100	17.0	21.6	26.3	40.3	40.3	49.7
104	17.6	22.4	27.3	42.0	42.0	51.6
108	18.3	23.3	28.4	43.6	43.6	53.6
112	19.0	24.2	29.4	45.2	45.2	55.6
116	19.7	25.0	30.5	46.8	46.8	57.6
120	20.4	25.9	31.5	48.4	48.4	59.6
124	21.0	26.8	32.6	50.0	50.0	61.6
128	21.7	27.6	33.6	51.6	51.6	63.6
132	22.4	28.5	34.7	53.3	53.3	65.5
136	23.1	29.3	35.7	54.9	54.9	67.5
140	23.8	30.2	36.8	56.5	56.5	69.5
144	24.4	31.1	37.8	58.1	58.1	71.5
148	25.1	31.9	38.9	59.7	59.7	73.5
152	25.8	32.8	39.9	61.3	61.3	75.5
156	26.5	33.7	41.0	62.9	62.9	77.5
160	27.1	34.5	42.0	64.6	64.6	79.4

Table D2 - Rectangular Duct Lbs per Foot, No Insulation (Stainless Steel)

Height + Width [in]	26 GA	24 GA	22 GA	20 GA	18 GA	16 GA
20	3.5	4.4	5.4	8.3	8.3	10.2
24	4.2	5.3	6.5	10.0	10.0	12.3
28	4.9	6.2	7.6	11.6	11.6	14.3
32	5.6	7.1	8.7	13.3	13.3	16.4
36	6.3	8.0	9.7	15.0	15.0	18.4
40	7.0	8.9	10.8	16.6	16.6	20.4
44	7.7	9.8	11.9	18.3	18.3	22.5
48	8.4	10.7	13.0	19.9	19.9	24.5
52	9.1	11.6	14.1	21.6	21.6	26.6
56	9.8	12.4	15.1	23.3	23.3	28.6
60	10.5	13.3	16.2	24.9	24.9	30.7
64	11.2	14.2	17.3	26.6	26.6	32.7
68	11.9	15.1	18.4	28.2	28.2	34.8
72	12.6	16.0	19.5	29.9	29.9	36.8
76	13.3	16.9	20.6	31.6	31.6	38.8
80	14.0	17.8	21.6	33.2	33.2	40.9
84	14.7	18.7	22.7	34.9	34.9	42.9
88	15.4	19.5	23.8	36.5	36.5	45.0
92	16.1	20.4	24.9	38.2	38.2	47.0
96	16.8	21.3	26.0	39.9	39.9	49.1
100	17.5	22.2	27.0	41.5	41.5	51.1
104	18.2	23.1	28.1	43.2	43.2	53.2
108	18.9	24.0	29.2	44.9	44.9	55.2
112	19.6	24.9	30.3	46.5	46.5	57.2
116	20.3	25.8	31.4	48.2	48.2	59.3
120	21.0	26.7	32.5	49.8	49.8	61.3
124	21.7	27.5	33.5	51.5	51.5	63.4
128	22.4	28.4	34.6	53.2	53.2	65.4
132	23.1	29.3	35.7	54.8	54.8	67.5
136	23.8	30.2	36.8	56.5	56.5	69.5
140	24.5	31.1	37.9	58.1	58.1	71.5
144	25.1	32.0	38.9	59.8	59.8	73.6
148	25.8	32.9	40.0	61.5	61.5	75.6
152	26.5	33.8	41.1	63.1	63.1	77.7
156	27.2	34.7	42.2	64.8	64.8	79.7
160	27.9	35.5	43.3	66.4	66.4	81.8

Table D3 - Rectangular Duct Lbs per Foot, No Insulation (Aluminum)

Height + Width [in]	26 GA	24 GA	22 GA	20 GA	18 GA	16 GA
20	1.2	1.5	1.8	2.8	2.8	3.5
24	1.4	1.8	2.2	3.4	3.4	4.2
28	1.7	2.1	2.6	3.9	3.9	4.9
32	1.9	2.4	2.9	4.5	4.5	5.6
36	2.1	2.7	3.3	5.1	5.1	6.2
40	2.4	3.0	3.7	5.6	5.6	6.9
44	2.6	3.3	4.0	6.2	6.2	7.6
48	2.8	3.6	4.4	6.8	6.8	8.3
52	3.1	3.9	4.8	7.3	7.3	9.0
56	3.3	4.2	5.1	7.9	7.9	9.7
60	3.6	4.5	5.5	8.5	8.5	10.4
64	3.8	4.8	5.9	9.0	9.0	11.1
68	4.0	5.1	6.2	9.6	9.6	11.8
72	4.3	5.4	6.6	10.2	10.2	12.5
76	4.5	5.7	7.0	10.7	10.7	13.2
80	4.7	6.0	7.3	11.3	11.3	13.9
84	5.0	6.3	7.7	11.8	11.8	14.6
88	5.2	6.6	8.1	12.4	12.4	15.3
92	5.5	6.9	8.4	13.0	13.0	16.0
96	5.7	7.2	8.8	13.5	13.5	16.7
100	5.9	7.5	9.2	14.1	14.1	17.4
104	6.2	7.8	9.5	14.7	14.7	18.0
108	6.4	8.1	9.9	15.2	15.2	18.7
112	6.6	8.4	10.3	15.8	15.8	19.4
116	6.9	8.7	10.6	16.4	16.4	20.1
120	7.1	9.0	11.0	16.9	16.9	20.8
124	7.4	9.4	11.4	17.5	17.5	21.5
128	7.6	9.7	11.8	18.0	18.0	22.2
132	7.8	10.0	12.1	18.6	18.6	22.9
136	8.1	10.3	12.5	19.2	19.2	23.6
140	8.3	10.6	12.9	19.7	19.7	24.3
144	8.5	10.9	13.2	20.3	20.3	25.0
148	8.8	11.2	13.6	20.9	20.9	25.7
152	9.0	11.5	14.0	21.4	21.4	26.4
156	9.2	11.8	14.3	22.0	22.0	27.1
160	9.5	12.1	14.7	22.6	22.6	27.8

Appendix E. Oval Duct Weight Estimation

To quickly estimate the weight of an oval duct it is acceptable to assume the oval is a rectangle and use the rectangular tables. The diagram below shows the height and width values for use in the rectangular tables. This method will safely overestimate the weight of the duct.

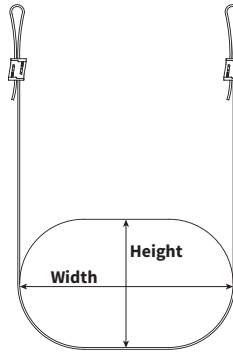



Ductmate.com | 1-800-245-3188

**210 5th Street
Charleroi, PA 15022**

