

Imported By:



390 EAGLE DR.
WINNIPEG, Manitoba
CANADA R3C 2E6
Toll Free: 1-800-665-8089
Ph#: 204-779-7791
Fax#: 204-779-7796

Email: sales@empire-machinery.com
Web: www.empire-machinery.com

Instruction & Parts Manual for

EMT-7R

Power Rotary Machine

Operator must read and understand
Instruction Manual prior to operating the
EMT-7R Power Rotary Machine, as damage
to machine or personal injury may result.

Electrician must refer to electrical schematics in
this manual before initial startup.

If any of these EMT-7R safety labels are missing from the machine or damaged, it is the owner's responsibility to contact Empire Machinery & Tools Ltd. immediately for replacement labels.



ROTARY MACHINE SAFETY RULES

- EMT-7R machine should be DISCONNECTED from power source before servicing.
- Never place any part of the body including loose clothing near or onto the rotating rolls. (KEEP HANDS AWAY). Failure to follow this procedure will lead to personal body injury.
- Never clean forming rolls while they are rotating.
- Do not exceed specified material capacity of the machine.
- Machine must be operated by authorized personal who have been trained in regards to working and safety features of the machine.

All operators must read and understand the Operators Manual.

- Never operate machine with any guards removed.
- Do not use machine if service is required.
- Use safety glasses and required protective equipment.
- Keep work areas clean and in proper order.

It is the responsibility of the owner of this machine and shop supervisor to ensure that all operators of this machine are properly trained on the safe operation of this machine and to require that this manual including the above Safety Rules are read by all machine operators prior to operating.

If any of the EMT-7R safety labels are missing from the machine or damaged, it is the owner's responsibility to contact Empire Machinery & Tools Ltd. immediately for replacement labels. See sample labels – OVER -)

START UP/OPERATION INSTRUCTIONS

WIRING

Prior to electrical hookup please refer to Wiring Schematic on next page.

CLEANING

Remove the factory applied rust inhibitor with a degreasing agent or oil soaked rags.

LUBRICATION

Check gearbox Oil Sight Glass (2) for proper oil levels

The following tables will provide you with manufacturers and types of oil and grease recommended by the factory.

Lubricate all points as marked with the proper grease using the fitting included in this information package.

US GREASE & OIL SPECIFICATIONS

BRAND	GREASE	OIL
US Mobil Brand	Mobilux Grease 2	Mobil DTE 24
Shell OilUS Product Info#1- 800-231-6950	Alvania EP2Alvania Gerase 2	Shell Tellus 32
Esso	Lonax/Lidok EP2	Nuto H32

CANADIAN GREASE & OIL SPECIFICATIONS

BRAND	GREASE	OIL
Nemco Available in: Winnipeg, Regina, Saskatoon	LCEP2	Hydrol AW32
Shell Canada	Alvania EP2Alvania Grease 2	Shell Tellus 32
Esso	Lonax/Lidok EP2	Nuto H32

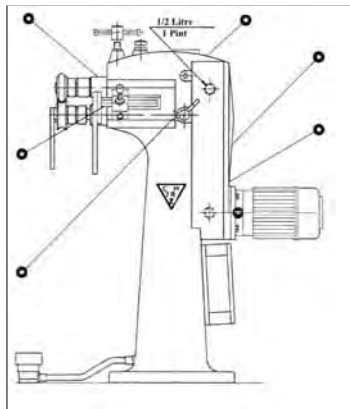

ELECTRICAL INSTALLATION

EMT-7R Power Rotary Machine Must Be Installed By a Certified Electrician

Please see wiring schematics for proper location to run your power lines to.
(FAILURE TO WIRE ACCORDING TO WIRING SCHEMATICS WILL RESULT IN INVERTER DAMAGE)

ROLL INSTALLATION

The EMT-7R comes with a lower shaft adjustment (14) so rolls with differing centerlines can be lined up. Loosen the locking screw on the right hand side of the unit (12) and then bring the rolls together. Once the rolls have fit snugly together firmly lock the shaft in place.

THROAT GAUGE ADJUSTMENT

The EMT-7R is fitted with adjustable Throat Gauge Guides. For operation of machine where limited throat gauge depth is required the guides should be located to the front of the of the shafts. Where deeper operations are required the Throat Gauge Guides must be removed and placed in their proper locations near the back of the shafts.

DEPTH CONTROL

The EMT-7R comes standard with a manual screw adjustment for control of the upper shaft depth. (9). If you look directly behind the Adjusting Screw you will see the Upper Shaft Tensioning Screw (10). This is factory set and should never need adjustment.

ROLL INSTALLATION

Rolls must be secured by means of the Roll Locking Nuts (5) provided.
Upper Roll Lock Nut is Left Hand Thread and the Lower Roll Lock Nut is Right Hand Thread.
Failure to secure rolls will result in roll and shaft damage and will void all factory warranties.

EMT-7R comes with a set of 3/8" Single Bead Rolls as standard.
(We will quote on any roll application you may require)

SPEED CONTROL

Your EMT-7R is equipped with a Speed Control and Forward/Reverse Switch. Forward/Off/Reverse Switch must be in either Forward or Reverse position to operate. Machine will only run if foot pedal is depressed. Operator should never switch between forward and reverse while the rolls are turning as damage may occur. Speed may be adjusted while rolls are turning.

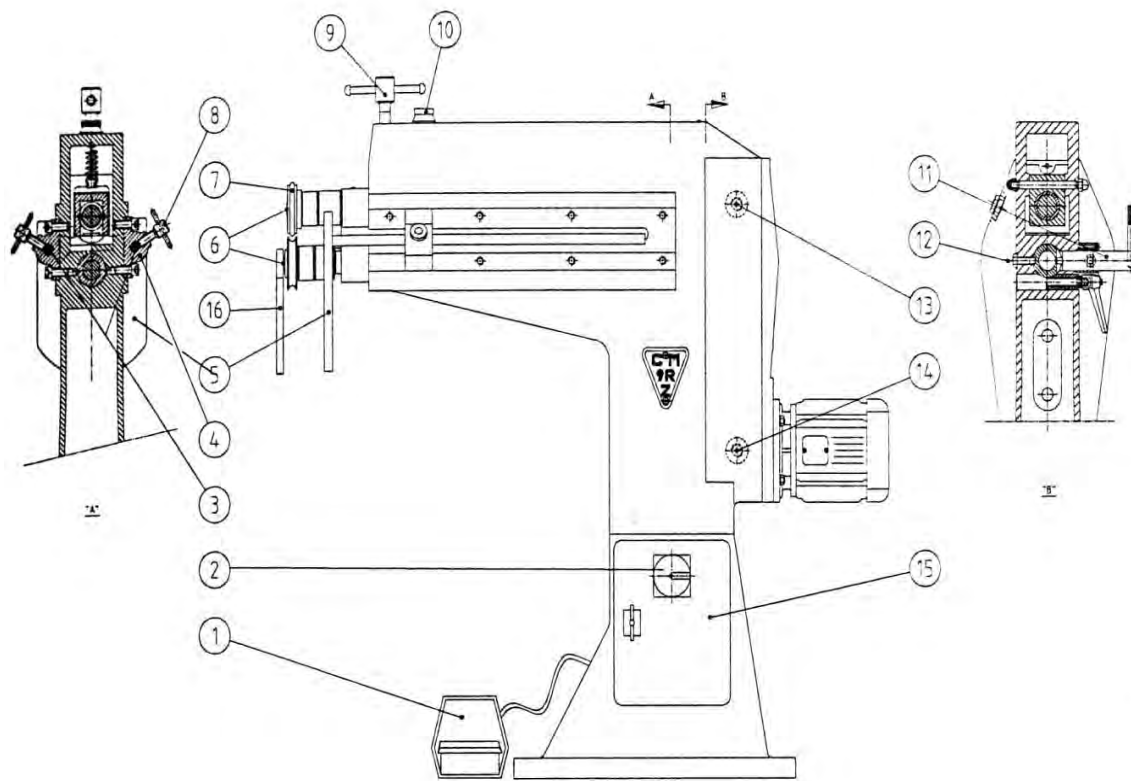

- 1 Switching pedal
- 2 Main disconnect switch
- 3 Axis guide supporting
- 4 Front guide supporting
- 5 Guide on front end
- 6 Right and left nuts
- 7 Shaping rollers
- 8 Guide locking screw
- 9 Nut for locking downward displacement limit height
- 10 Spring capsule
- 11 Displacement control
- 12 Lower spindle locking screw
- 13 Gearbox plug
- 14 Oil level
- 15 Electric box

EMT-7R Parts Breakdown

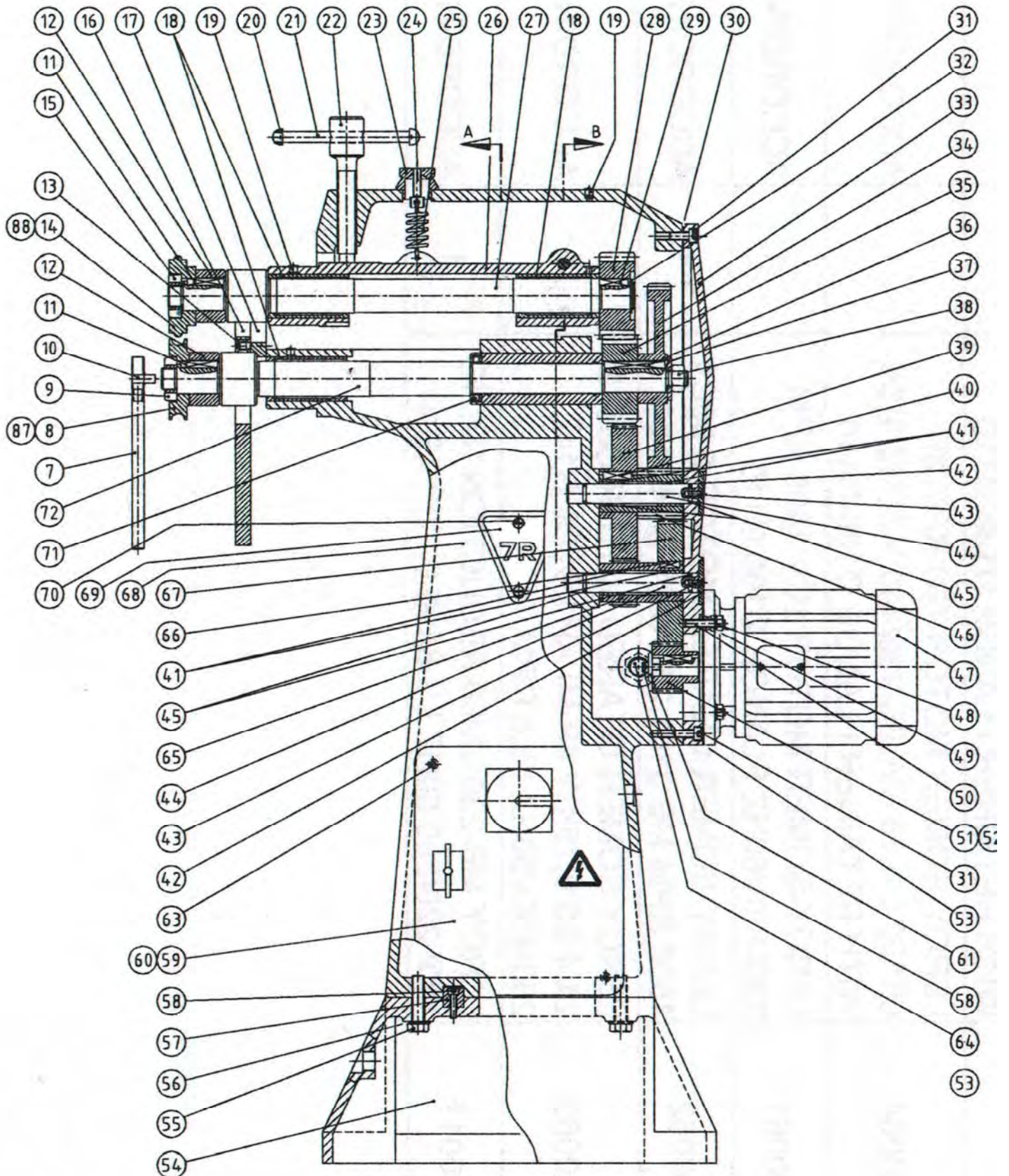

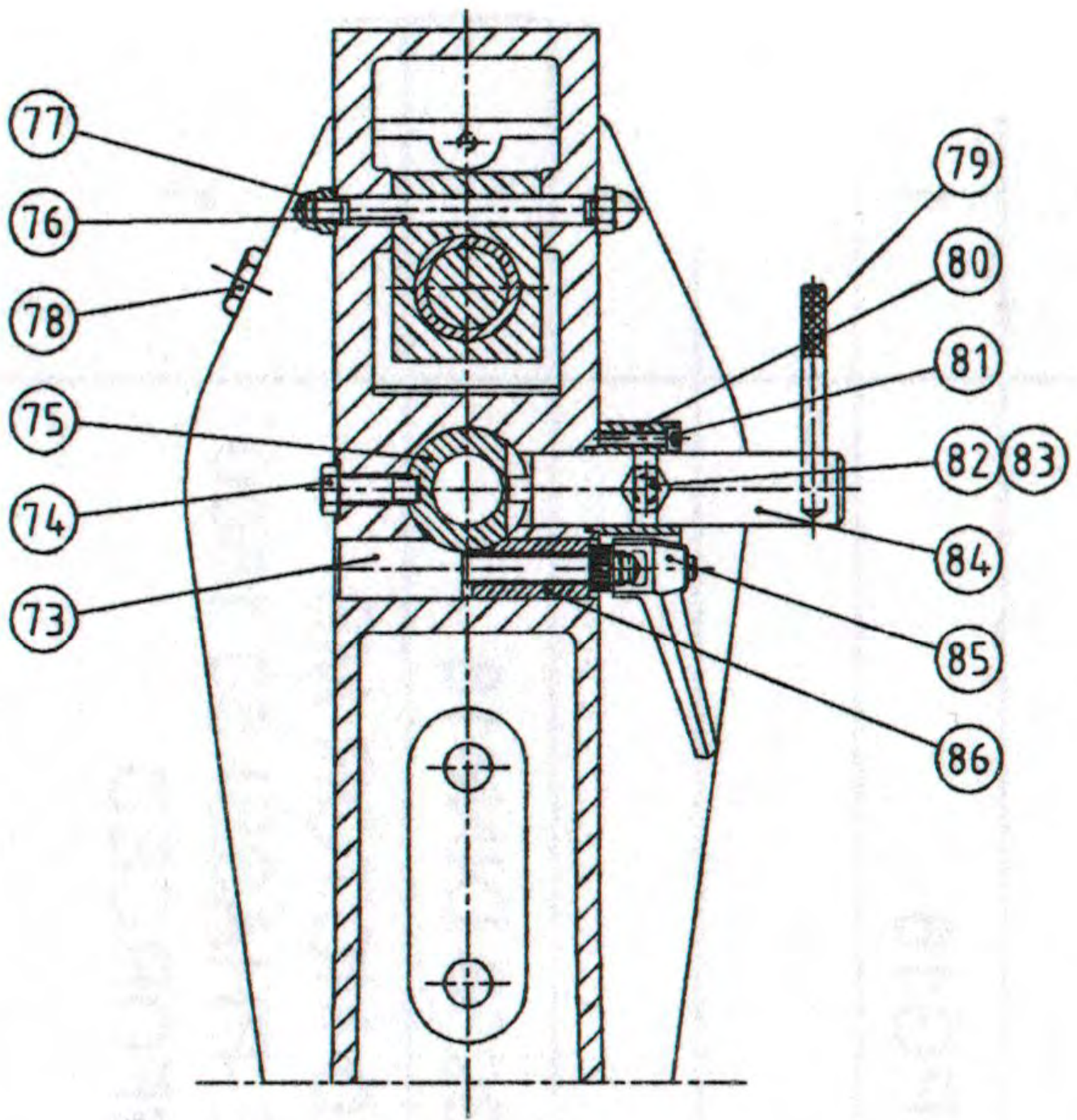

"B"

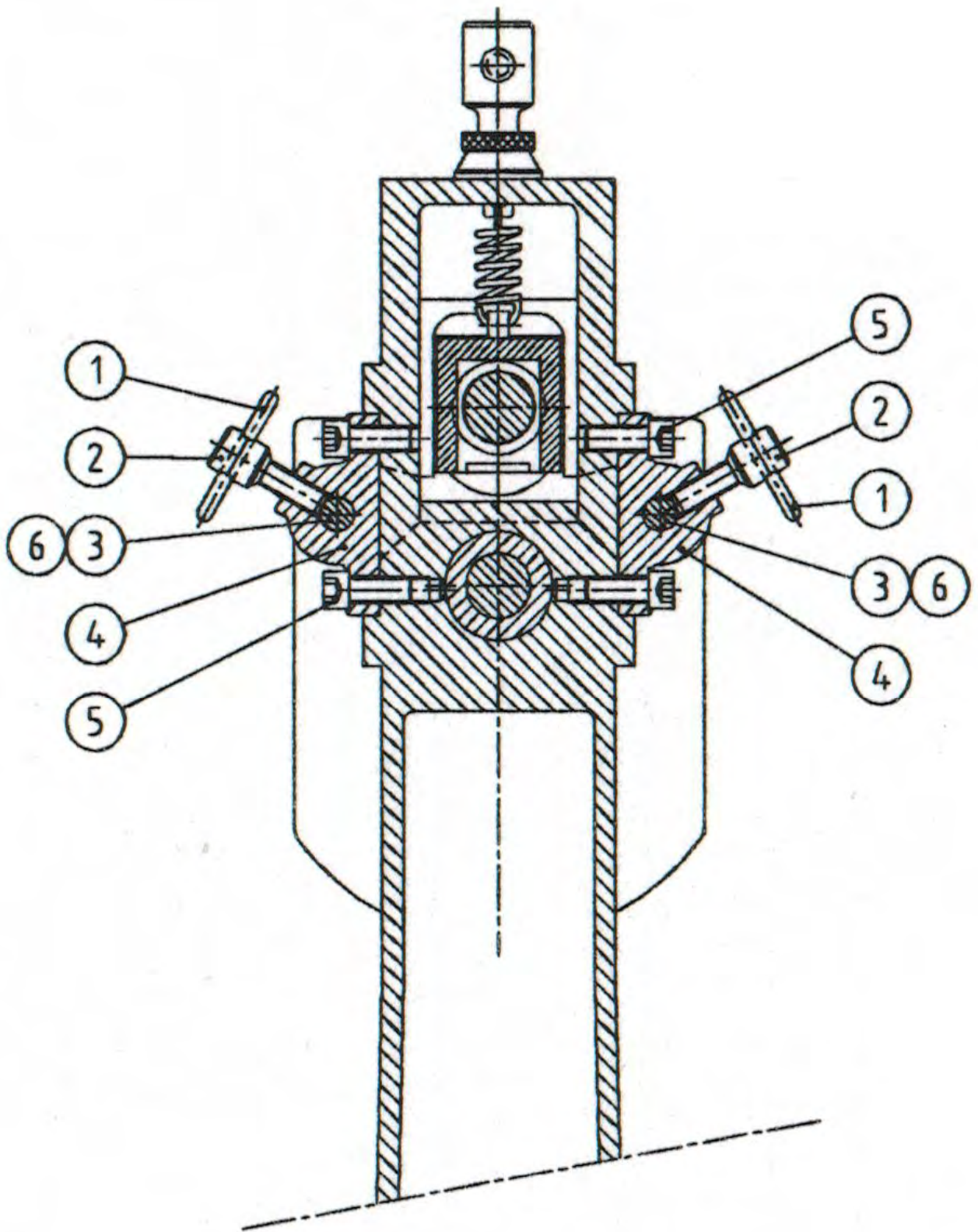

"A"

Nr.	Code	Description	Quant.	Comments
1	UN7/00321	ROD DE 00320	2	
2	UN7/00320	EAR SCREW	2	
3	UN7R/00418	LONG FRONT COVER BAR	2	
4	UN7/00312	EAR	2	
5	350.15.00975	CYLINDRICAL HEAD SCREW M12x30 DIN 912-12.9	4	
6	UN7R/00418A	SHORT FRONT PLATE ROD	2	
7	UN7/00324A	KEY ROD	1	
8	UN7/00350	LOWER SHEAVE NO. 5	1	
9	UN7/00322	RIGHT-HAND NUT	1	
10	UN7/00324	KEY HEAD	1	
11	350.18.00385	ADJUSTMENT TONGUE A 8X7X36 DIN6885	2	
12	UN7/00313	OUTSIDE BUSHING	2	
13	350.15.03317	COUNTERSUNK SCREW M8X25 DIN7991	2	
14	UN7/00333	UPPER SHEAVE NO. 5	1	
15	UN7/00323	LEFT-HAND NUT	1	
16	UN7/00311	SHIELD	1	SPECIALS: UN7/00311C - UN7/00311A
17	UN7R/00419	FRONT PLATE	1	
18	UN7R/00421	BRONZE BEARING EN 00401 AND 00402	3	
19	350.20.0326	BALL LUBRICATOR Ø8 RFA.A-862	3	
20	UN7/00315A	HEAD DE 00315	2	
21	UN7/00315	ROD DE 00314	1	
22	UN7/00314	UPPER SCREW	1	
23	UN7/00316	SPRING ADJUSTMENT NUT	1	
24	UN7/00317	SPRING SCREW	1	
25	UN7/00327	SPRING	1	
26	UN7R/00402	SQUARE BEARING	1	
27	UN7R/00425	TOP AXIS	1	
28	UN7R/00429	GEAR Z=18 UPPER	1	
29	350.18.00365	ADJUSTMENT TONGUE A 8X7X28 DIN6885	1	
30	UN7R/00437	FRAME COVER SEAL	1	
31	350.15.00495	CYLINDRICAL HEAD SCREW M8X20 DIN 912-12.9	6	
32	350.15.0643	SEEGER RING, E-28 DIN 471	1	
33	UN7R/00406A	GEARBOX COVER	1	
34	UN7R/00410	GEAR Z=63	1	
35	UN7R/00427	GEAR Z=18 LOWER	1	
36	350.18.0042	ADJUSTMENT TONGUE A 8X7X60 DIN6885	1	
37	UN7R/00435	LOWER AXLE WASHER	1	
38	350.15.0513	HEXAGONAL NUT M16 DIN935	1	
39	UN7R/00408A	GEAR Z=68	1	
40	350.18.0047	ADJUSTMENT TONGUE A 10X8X28 DIN6885	1	
41	UN7R/00420	FRAME BUSHING	4	
42	UN7R/00446	RETAINING COVER	2	
43	350.15.0324	COUNTERSUNK-HEAD SCREW M5x12 DIN 7991	6	
44	UN7R/00428A	COVER LOWER AXLE	2	
45	350.21.0088	JUNTA TORICA AN-12 DIN6227	4	
46	UN7R/00409A	GEAR Z=16	1	
47	350.02.0001	LEROY-SOMER MOTOR 1500 RPM.4P LS80 L 0,75 KW.B5 230/400 V.50HZ.IP55 WITH RETAINER FLANGE Ø160-Ø110	1	
48	350.15.0509	HEXAGONAL NUT M8 DIN935	4	
49	350.15.0586	WASHER 8,4 DIN125	4	
50	350.15.03785	THREADED BAR M8X40 DIN913	4	

Nr.	Code	Description	Quant.	Comments
51	UN7R/00404	GEAR MOTOR	1	
52	UN7R/00404E	GEAR MOTOR	1	ENGLAND
53	UN7R/00438	MOTOR FLANGE-GEARBOX COVER SEAL	1	
54	UN7R/00411	BASE OF FRAMEWORK	1	
55	350.15.0193	HEXAGONAL HEAD SCREW M12X50 DIN933	4	
56	350.15.0588	WASHER 13 DIN125	4	
57	TBI480/01047	COLUMN SUPPORT PLATE KEY (MAHLE)	1	
58	350.15.00315	CYLINDRICAL HEAD SCREW M6X25 DIN 912-12.9	3	
59	500.02.0142	HIMEL DBNX-25/20 STEEL SHEET CABINET	1	
60	500.01.0143	HIMEL PMD-25/20 PLACA MONTAJE ARMARIO METALICO	1	
61	UN7/00345	MOTOR PULLEY WASHER	1	UN7R/00440 (ENGLAND)
63	350.15.00295	CYLINDRICAL HEAD SCREW M6X16 DIN 912-12.9	4	
64	350.19.0030	VISOR MACIZO EXAGONAL 28MM. ROSCA 1/2"	1	
65	UN7R/00407A	GEAR Z=22	1	
66	350.18.0036	ADJUSTMENT TONGUE A 8X7X20 DIN6885	1	
67	UN7R/00405A	GEAR Z=62	1	
68	UN7R/00401A	FRAMEWORK	1	
69	UN7R/00417	LABEL CMZ 7R	1	
70	350.15.0276	COUNTERSUNK-HEAD SCREW M6X15 DIN63	2	
71	350.04.0114	BEARING N° 51106	1	
72	UN7R/00426	LOWER AXIS	1	
73	UN7R/00432	LOCKING SPINDLE	1	
74	UN7R/00431	ROTATION PREVENTION SCREW	1	
75	UN7R/00403	CYLINDRICAL BEARING	1	UN7R/00403A (SPECIAL)
76	UN7/00340A	SQUARE BEARING ROTATION ROD	1	
77	350.15.05788	DOMED NUT M10 DIN1587	2	
78	350.19.0058	ELESA PLUG TCD 1/2 BLACK CODE 58621	1	
79	UN7/00337	ECCENTRIC ROD	1	
80	UN7R/00445	DISPLACEMENT CONTROL SUPPORT	1	
81	350.15.00335	CYLINDRICAL HEAD SCREW M6x35 DIN 912-12.9	4	
82	350.15.0574	HEXAGONAL NUT M12 DIN937	1	
83	350.15.04974	THREADED BAR M12X40 DIN915	1	
84	UN7R/00415	ECCENTRIC	1	
85	350.19.0025	ELESA CLAMPING HANDLE MR 80A-M12 TYPE (FEMALE)	1	
86	UN7R/00433	LOCKING BUSHING	1	
87	UN7/00430	LOWER PULLEY SW-9	1	
88	UN7/00429	UPPER PULLEY SW-9	1	

Optional Accessories for EMT-7R

- Single Bead Rolls (3/16", 1/4", 1/2")
- HEAVY Crimping Rolls (1-1/2") 16GA/18GA
- HEAVY Combination Crimp & 3/8" Bead Rolls (Inc. Spacer to allow use of crimp rolls only)
- NEW! LIGHT Crimping Rolls (20GA & lighter)
- LIGHT Combination Crimp & 3/8" Bead Rolls (Inc. Spacer to allow use of crimp rolls only)
- Ogee Bead Rolls
- Flattening Rolls
- Elbow Edging
- Offset Rolls
- Burring Rolls
- 1/4" Flanging Rolls
- 1/2" #20 Smooth Flanging Rolls (20Ga. & Heavier)
- 1/2" #20 KNURLED Flanging Rolls (better on lighter gauges)
- Wiring - specify -1/16", 1/8", 3/16", 1/4", 5/16"
- Closing
- Slitting Rolls
- Spin In Collar Rolls (22GA & lighter)
- Base (Raises working height from 31-1/2 – 42")
- Optional Electrics: (440V 3PH)
- Air Cylinder Package c/w Depth Stop
(Raises & Lower Top Shaft with Foot Switch (Not to Be Used with #20 Flange Rolls or Spin In Rolls))
- Air Over Oil Hydraulic Cylinder (Foot Pedal Controlled)Top Shaft Control
- Digital Programmable Top Shaft Control
- Spring Loaded Pipe Support Stand
- Larger Front Face Plate c/w Internal Bearing Supports



Bead
1/8", 3/16", 1/4",
3/8", 1/2"



Optional Air Cylinder Op-
tion Allows for Hands
Free Operation

11" Throat Depth

Hardened Steel Back-
ing Plate

High Efficiency Motor Dual
Voltage Motor

Optional Speed Control gives
operator infinitely variable speed
and forward/reverse at the flip of
a switch

Optional Base Raises the
Standard Working Height
from 33" to 38"

Safety Covered
Footswitch



Offset



Slit



**Crimp or
Combination
Bead & Crimp**



**1/4" or 1/2" 90° Flange Rolls
(Pipe Stays in Horizontal Position)**

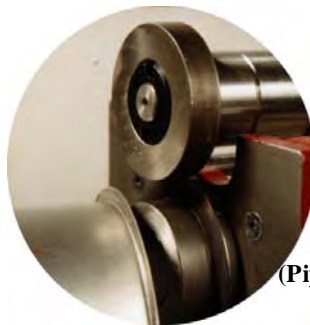

Offset Rolls

- With large spacers on the top and bottom shafts install the male offset roll on the top shaft and the female offset roll on the bottom shaft
- Tighten locking collars.
- Bring top shaft down until rolls are just touching.
- Loosen locking screw on the bottom shaft and adjust the bottom roll until there is about 2 times material thickness between the male and female portion of the rolls.
- Adjust the backstop up to the back of the bottom roll so it is almost touching the roll but not rubbing and lock in place.
- Place material onto the bottom roll and up against the backstop.
- Start the rolls turning and bring the top shaft down and form the offset.
- You may be required to do some minor adjustments to the spacing for optimum parts.

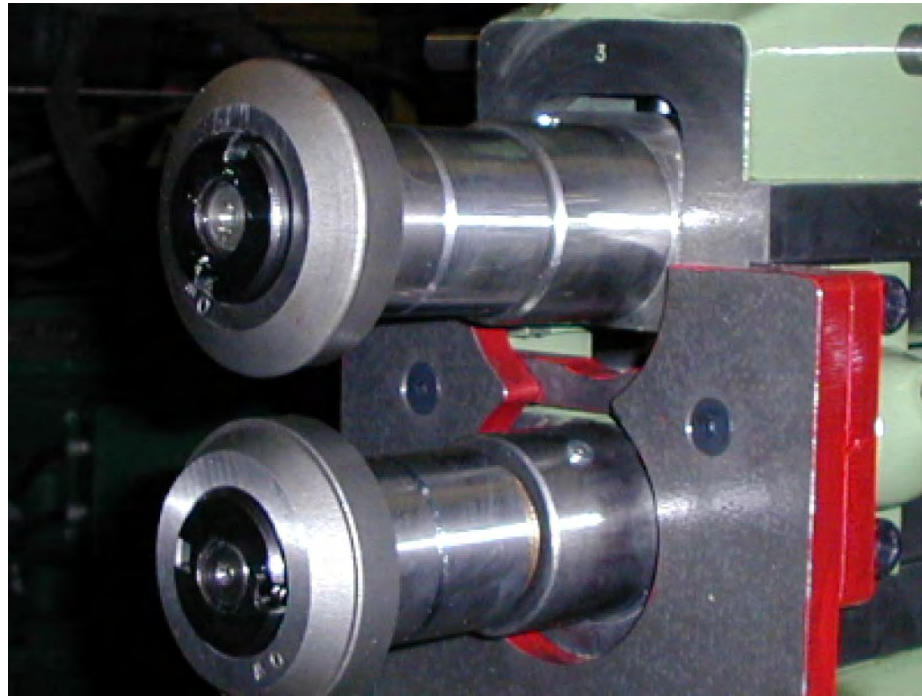

1/2" #20 Flange Rolls

- Install flat roll on the top shaft.
- Remove bottom spacing collar and install the threaded spacing collar.
- Loosen the bottom shaft locking screw and adjust shaft all the way in and then tighten the locking screw.
- Install roll with shoulder on the bottom shaft with the shoulder towards the backstop
- Bring the top roll down until the top and bottom roll just about touch.
- Adjust the threaded collar on the bottom shaft until there is about 2 times the material thickness spacing.
- Tighten the locking collars.
- Bring the backstop up to the shoulder on the bottom roll just so it does not rub on the roll.
- The capacity on the rolls is 14 Ga. To 22 Ga. If you are using lighter gauge material ie: 22 Ga. you must bring the top roll down slowly into the material otherwise you will wrinkle the material and it will not form.

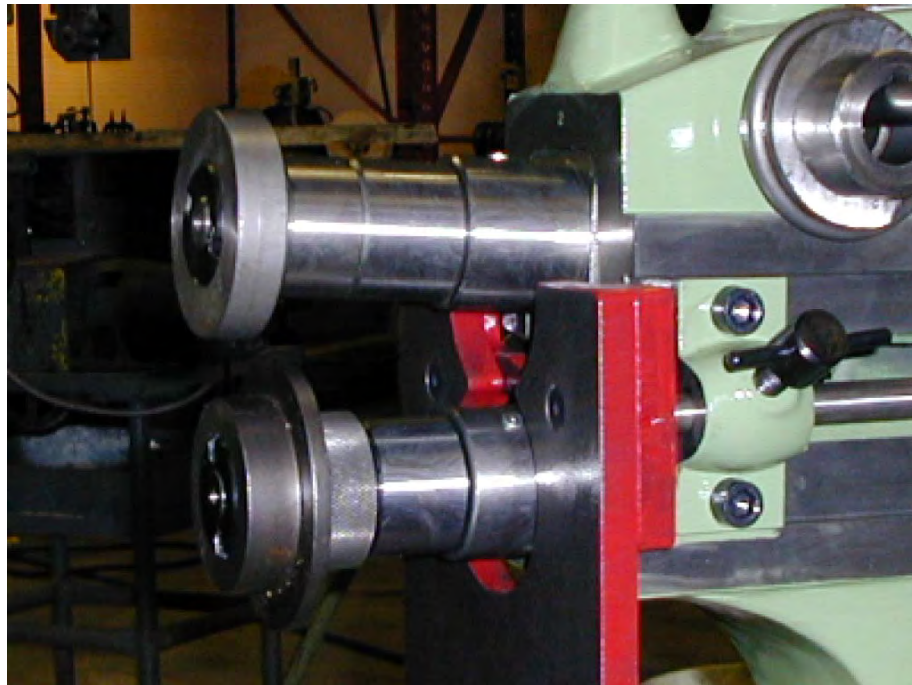

Crimp Rolls

- Remove the large shaft spacing collars on the top and bottom shaft
- Install the small spacers that came with the rolls on the shafts.
- Install the top and bottom crimp roll with the recess in the face of the roll to the front of the machine.
- Bring the top shaft down until the rolls mesh together.
- Tighten the locking collars.
- Adjust the backstop up to the end of the crimp rolls and tighten.
- When you are ready to form the crimp. With the rolls separated place your material over the bottom roll until the material is against the backstop.
- **DO NOT START THE MACHINE UNTIL YOU BRING THE TOP ROLL DOWN AND TIGHTEN FIRMLY TOGETHER SANDWICHING THE MATERIAL BETWEEN THE ROLLS.**
- You can now press on the footswitch and begin the crimping process.

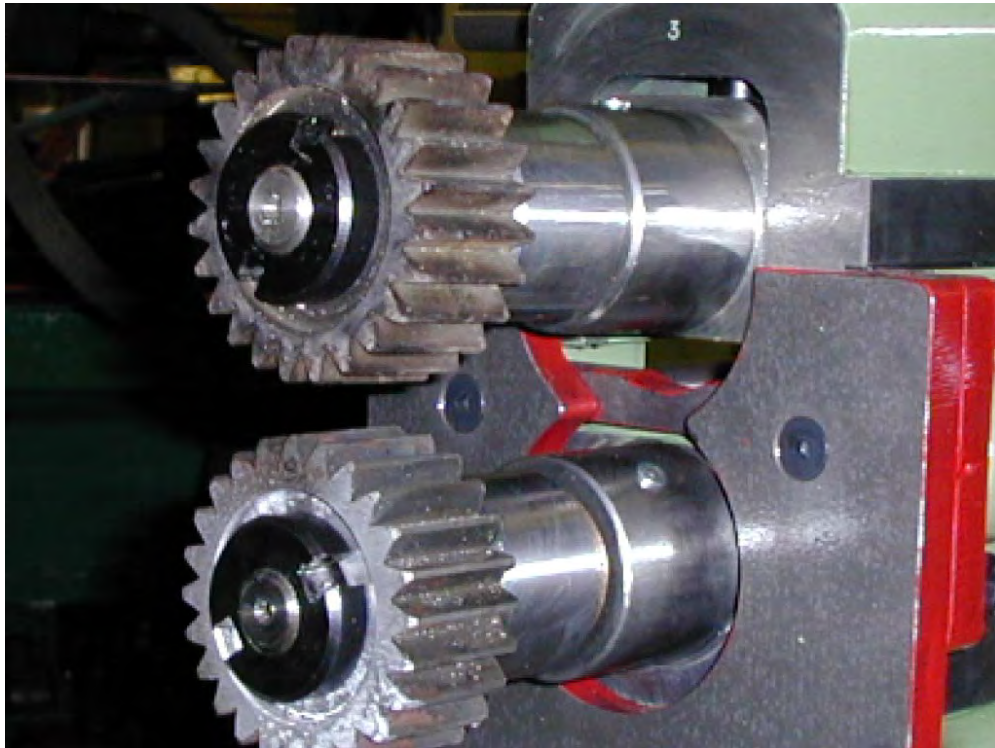

Combination Bead & Crimp

- Remove the large shaft spacing collars on the top and bottom shaft
- Install the top and bottom crimp rolls with the recess in the face of the roll to the back of the shaft.
- Install the male bead roll on the bottom shaft with the highest portion of the roll facing out.
- Install the female bead roll on the top shaft with the highest portion of the roll facing out.
- Bring the top shaft down until the rolls mesh together.
- Tighten the locking collars.
- Adjust the backstop up to the end of the crimp rolls and tighten.
- When you are ready to form the crimp. With the rolls separated place your material over the bottom roll until the material is against the backstop.
- **DO NOT START THE MACHINE UNTIL YOU BRING THE TOP ROLL DOWN AND TIGHTEN FIRMLY TOGETHER SANDWICHING THE MATERIAL BETWEEN THE ROLLS.**
- You can now press on the footswitch and begin the crimping process.

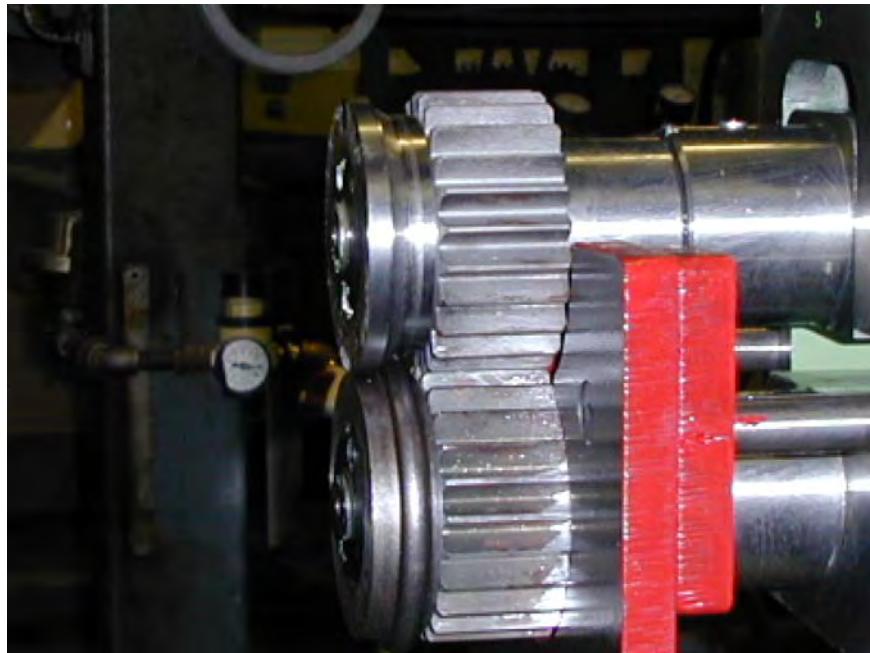

EMT-7R Air Cylinder Operation

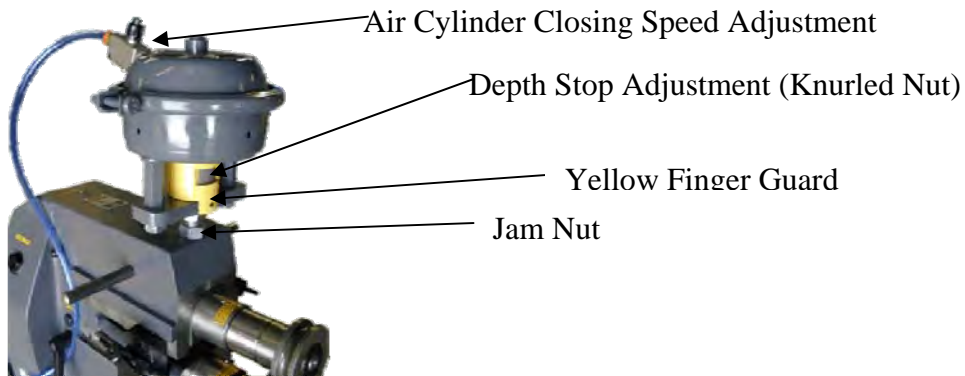

The EMT-7R Air Cylinder option is a cost effective way of allowing the operator hands free operation to maintain full control of the part being formed. This option is **not recommended** for Flanging Rolls or Spin In Collar Rolls as these rolls require a stepping down of the top shaft and the travel on the air cylinder is continuous and not able to stop & start during the forming process which is a requirement for these rolls.

The air cylinder is initialized when the foot pedal is depressed and returns to its home position when the foot pedal is released.

The air cylinder option comes standard with a closing speed adjustment valve which is used to control the speed of the top shaft coming together to pinch the material. Also included is a depth stop adjustment which allows the operator to stop the top shaft at a predetermined depth for production operations. To adjust the air cylinder to the desired depth use your thumb and adjust the Knurled Nut which is located inside the window of the yellow finger guard. Screwing the Knurled Nut down will shorten the stroke of the cylinder and lessen the depth of the profile being formed. Raising the Knurled Nut will allow the rolls to come closer together thereby allowing the profile to be deeper.

If for any reason the air cylinder must be removed to allow the operator to utilize the standard hand crank that was shipped with your EMT-7R the following process must be followed. First disconnect the air supply from your compressor to the unit. Then remove the plastic air line from the top of the air cylinder that is connected to the end of the speed control valve by pushing and holding the plastic ring in while pulling on the air line. Next loosen the jam nut (shown in the picture above) and then spin the air cylinder out of the threaded hole and thread in the hand crank.

EMT-7R Programmable Top Shaft Control

The PLC Control for the top shaft on the EMT-7R is a single program control that utilizes intervals of air being introduced to the air over oil hydraulic system and wait times between each burst of air. The control has two different operating modes and they are explained as follows:

MANUAL: In manual mode the top shaft is controlled by means of either pushing the **UP** or **DOWN** buttons on the keypad. Very few of the other buttons on the keypad will function when in manual mode.

AUTOMATIC: In automatic mode the manual up and down function buttons on the keypad are not useable. After a program is entered and the home position is set then the foot pedal is activated and must remain activated until the end of the program. If the foot pedal is released before the end of the program then the top shaft will return to its home position and will begin at the start of the program.

PROGRAMMING THE CONTROL: Each part may vary and must be programmed with this in mind. Some parts require a full revolution before the top shaft can be fed down i.e. Spin-In Collar and ½" Flange Rolls. With this in mind you will need to vary your speed of the rolls to match the settings on the control. This can only be done with a little bit of trial and error. There are three different settings that make up a program and they are as follows:

INDEX TIME: This is the amount of time that air will be introduced to the system thereby driving the top shaft down with each burst of air. The shorter the time the larger the number of steps will be required to get to the bottom of the stroke. **NOTE:** There is less than 1" of stroke required to get from the top of the stroke to the bottom. The number should never have to be much longer than ½ a second for a simple part like a bead or a fraction of a second for the spin collar rolls.

WAIT TIME: This is the amount of time required between the bursts of air. This number will be set according to the diameter of part and if the part requires a full revolution or not before the next downward movement of the top shaft.

INDEX #: This number is the number of downward movements of the top shaft is required to complete the program and the part. Once the control has counted this number of movements you will be instructed to release the foot pedal. This number is also a trial and error number that must be set by trying a part to determine the required movements of the top shaft to finish the part. **NOTE:** This number may need to be adjusted if you set the program without running material for purposes of setup.

The **ARROW KEYS**  are used to navigate between each setting and the **CLR** button clears the existing numbers. Using the numbers on the pad enter the required setting and then press **ENTER**. **NOTE:** If **ENTER** is not pressed after each change the number will not be accepted.

HOME: This button returns the top shaft to a preset home position no matter what mode or position the top shaft is in.

LEARN HOME: This button teaches the control the home position. **Extra care must be taken when entering the values in this area, as severe damage will occur to the machine as over travel may occur if too large a value is entered.** To program the home position press the **LEARN HOME** button on the keypad. Doing this will take you into a different screen, there will be three different settings that can be changed on this screen and they are explained as follows:

RISE TIME: This value is the time that the control allows for the top shaft to rise after the program is finished or the **HOME** button is pushed.

WAIT TIME: This value is the wait time allowed after the top shaft reaches the top of stroke. This value is important as some different roll profiles may take more time than others to remove the part from the rolls.

DOWN TIME: This value is the time allowed for the top shaft to return to its home position. Careful attention must be made when entering this value as damage to the machine will occur if too long a value is place here. You should never have a value much longer that 3 seconds.

To program a new home position press **LEARN HOME** and then use the arrow buttons to move between the settings. Use the **CLR** button to clear each value and enter the new value. Remember to press **ENTER** after each change. Once you have made all the necessary changes you must press **LEARN HOME** to finish the teach function. You will now be back at the program screen and ready to run parts. To test your new home position press the **HOME** button.

REMEMBER THE EMERGENCY BUTTON SHUTS DOWN ALL THE FUNCTIONS ON THE MACHINE. IF YOU SENSE THAT SOMETHING IS NOT RIGHT PRESS THE RED EMERGENCY LOCATED ON THE PANEL ABOVE THE KEYPAD.

Air/Oil Hydraulic with Foot Pedal Control

The Air/Oil with foot pedal control uses the same feed system as the programmable control for the top shaft but the difference in the way it is actuated is by means of a two position foot pedal allowing hands free operation of the EMT-7R. There are two separate micro switches in the foot pedal and they operate as follows. When you press on the pedal halfway down the rolls begin to turn and then by pressing the pedal all the way to the floor you then activate the air/hydraulic system causing the top shaft to start traveling down. To jog the top shaft down and then hold it at a desired position just bring the pedal back to the halfway point and keep your foot there and the top shaft will stop its movement and hold in that position. To continue stepping down the top shaft you can lightly tap your foot to the floor and bring it back to the center position until the desired depth for your profile is achieved. Once your part is finished raise your foot completely off the foot pedal and the top shaft will return to its home position and the rolls will stop rotating. For repetitive parts where a certain depth is required for each part the stop nut on the top of the hydraulic cylinder can be turned up or down and can be used as an indicator to the operator that the desired depth has been reached.

****A pressure relief valve is part of the hydraulic package so it is safe to bring the rolls together under load where a larger amount of pressure is required to form your profile. Once the pressure builds to a set value the pressure relief valve will open and oil will bypass the cylinder and safely return to the tank.**

Electrical Schematics for Air/Oil Hydraulic Package

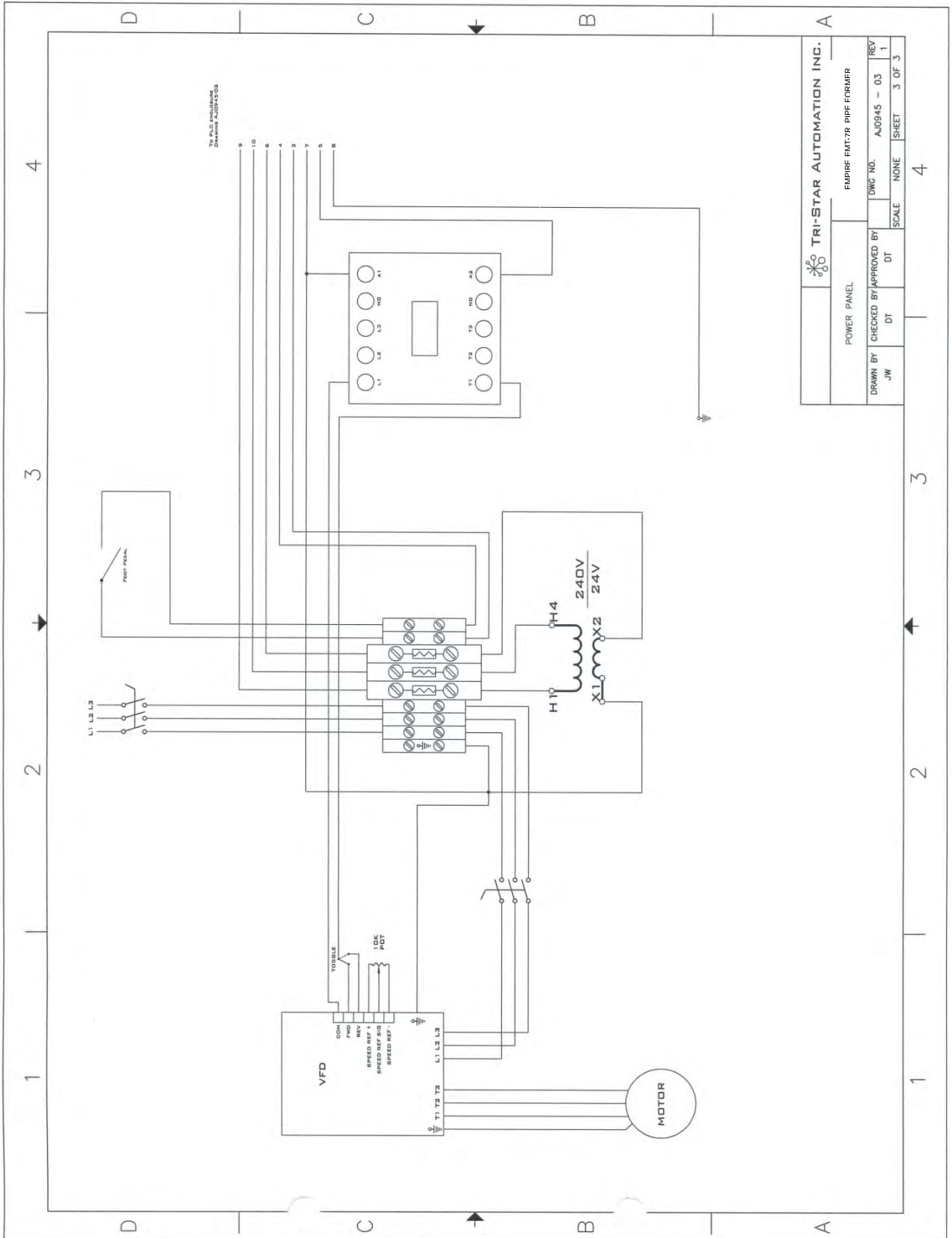

 TRI-STAR AUTOMATION INC.			
POWER PANEL		EMPIRE FMT7/R PIPF FORMER	
DRAWN BY J/W	CHECKED BY DT	DT	SCALE NONE
DWG NO. AJ0945 - 03	REV 1	SHEET 3 OF 3	REV 1

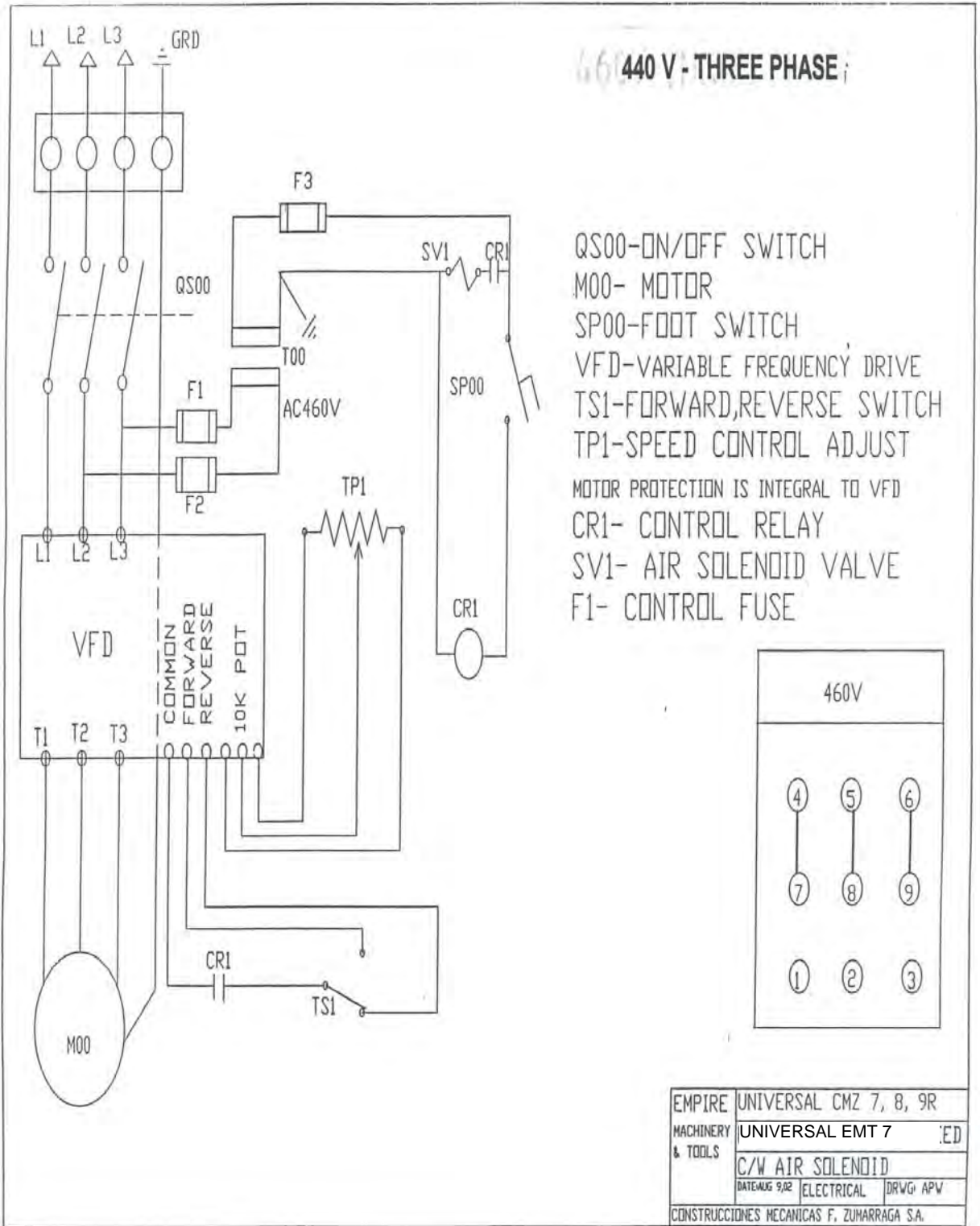

440 V - THREE PHASE ;

- QS00-ON/OFF SWITCH
- M00- MOTOR
- SP00-FOOT SWITCH
- VFD-VARIABLE FREQUENCY DRIVE
- TS1-FORWARD,REVERSE SWITCH
- TP1-SPEED CONTROL ADJUST
- MOTOR PROTECTION IS INTEGRAL TO VFD
- CR1- CONTROL RELAY
- SV1- AIR SOLENOID VALVE
- F1- CONTROL FUSE

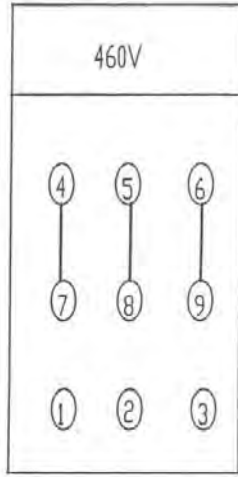

EMPIRE	UNIVERSAL CMZ 7, 8, 9R	
MACHINERY & TOOLS	UNIVERSAL EMT 7	'ED
	C/W AIR SOLENOID	
	DATE AUG 9, 02	DRWG APV
CONSTRUCCIONES MECANICAS F. ZUMARRAGA S.A.		

230V THREE PHASE

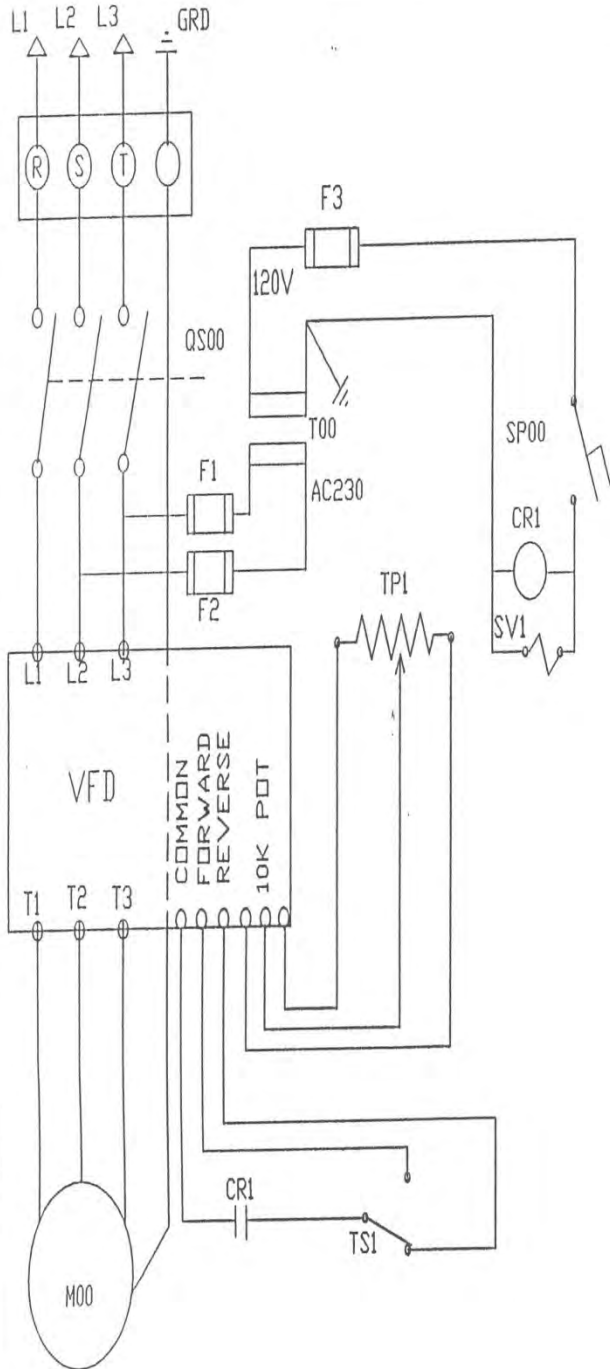

- QS00-ON/OFF SWITCH
- M00- MOTOR
- SP00-FOOT SWITCH
- VFD-VARIABLE FREQUENCY DRIVE
- TS1-FORWARD,REVERSE SWITCH
- TP1-SPEED CONTROL ADJUST
- MOTOR PROTECTION IS INTEGRAL TO VFD
- CR1- CONTROL RELAY
- SV1- AIR SOLENOID VALVE
- F1 & F2 XFMR LINE FUSES
- F3 - CONTROL FUSE

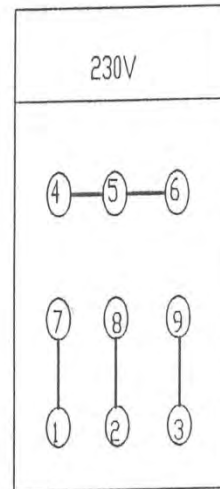

EMPIRE	UNIVERSAL EMT 7	
MACHINERY & TOOLS	FWD, REV, VARIABLE SPEED	
	C/W AIR SOLENOID	
DATE: AUG 9, 82	ELECTRICAL	DRWG: APW
CONSTRUCCIONES MECANICAS F. ZUMARRAGA S.A.		

230V SINGLE PHASE

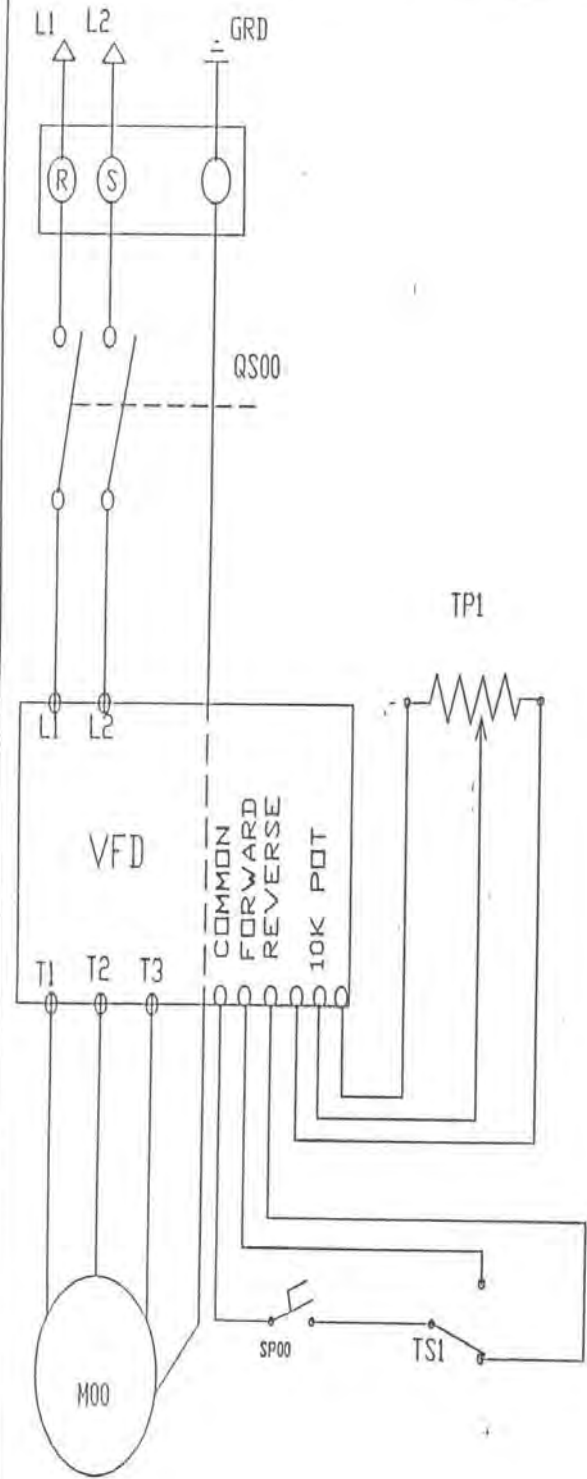

QS00-ON/OFF SWITCH
 M00- MOTOR
 SP00-FOOT SWITCH
 VFD-VARIABLE FREQUENCY DRIVE
 TS1-FORWARD,REVERSE SWITCH
 TP1-SPEED CONTROL ADJUST
 MOTOR PROTECTION IS
 INTEGRAL TO VFD

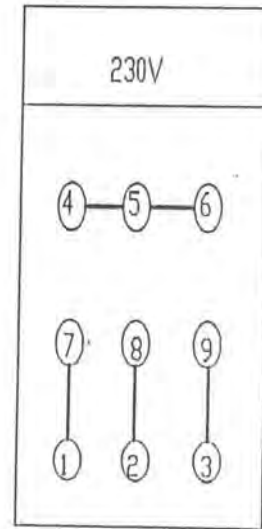

EMPIRE	UNIVERSAL EMT 7		
MACHINERY & TOOLS	FWD, REV, VARIABLE SPEED		
	NO AIR SOLENOID		
	DATE: AUG 9, 02	ELECTRICAL	DRWG: APV
CONSTRUCCIONES MECANICAS F. ZUHARRAGA S.A.			

110V SINGLE PHASE W AIR CYLINDER

- QS00 - ON/OFF SWITCH
- M00 - MOTOR
- SP00 - FOOT SWITCH
- VFD - VARIABLE FREQUENCY DRIVE
- TS1 - FORWARD, REVERSE SWITCH
- TP1 - SPEED CONTROL ADJUST
- MOTOR PROTECTION IS INTEGRAL TO VFD
- CR1 - CONTROL RELAY
- SV1 - AIR SOLENOID VALVE
- F1 & F2 XFMR LINE FUSES
- F3 - CONTROL FUSE

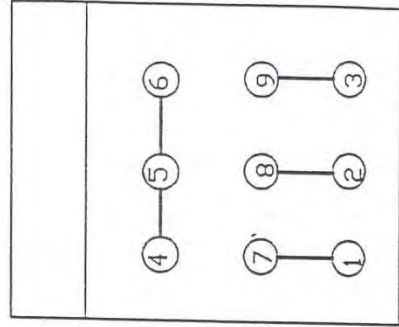
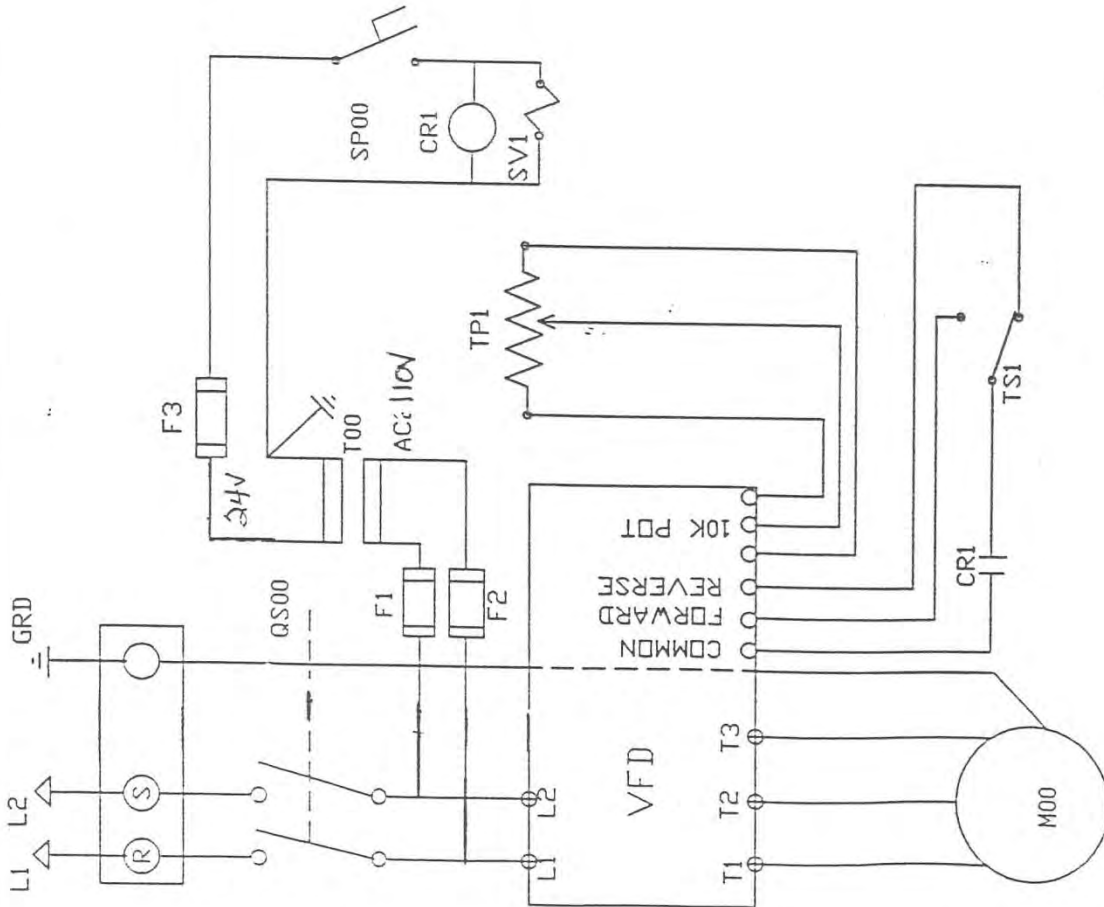

EMPIRE MACHINERY & TOOLS	UNIVERSAL EMT 7
FWD, REV, VARIABLE SPEED	
C/W AIR SOLENOID	
DATE: 06/9/02	DRWG: APV
ELECTRICAL	
CONSTRUCCIONES MECANICAS F. ZUMARRAGA S.A.	

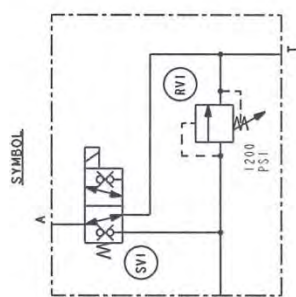
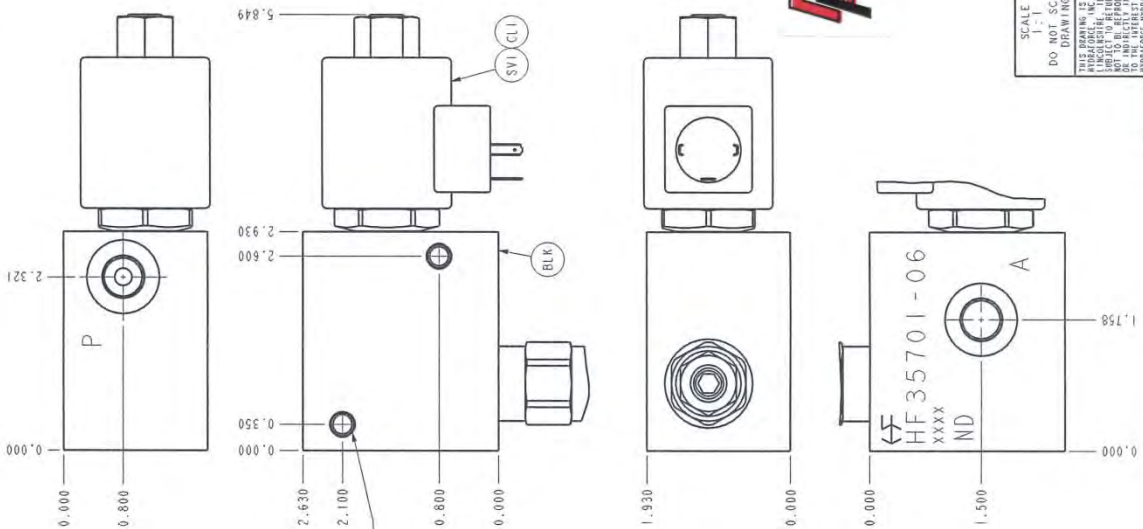

RAPID WEST
HYDRAULICS INC.
www.rapidwest.ca

1476 Wellington Avenue
Winnipeg, Manitoba R3E 0K5
Tel: (204) 783-2277
Fax: (204) 783-6416

PORTING:
ALL PORTS ARE SAE 06

SCALE: 1:1
DO NOT SCALE DRAWING

THIRD ANGLE PROJECTION

REGISTRATION: HYDRAFORCE®
COMBINATION VALVE 5954644

STANDARD AIR/OIL REPORTING NUMBER
SHEET 1 OF 1 REV 061824
HF35701-06 BY DATE 080207

UNIT: INCH

ITEM	QTY	MODEL NUMBER / DESC.
SVI	1	SV38-38-0-N-00
RV1	1	RV08-22A-0-N-25/12
CLI	1	COLL 6356024
NOT SHOWN	1	PLUG E108080
BLK	1	BLOCK 7182280

PARTS LIST

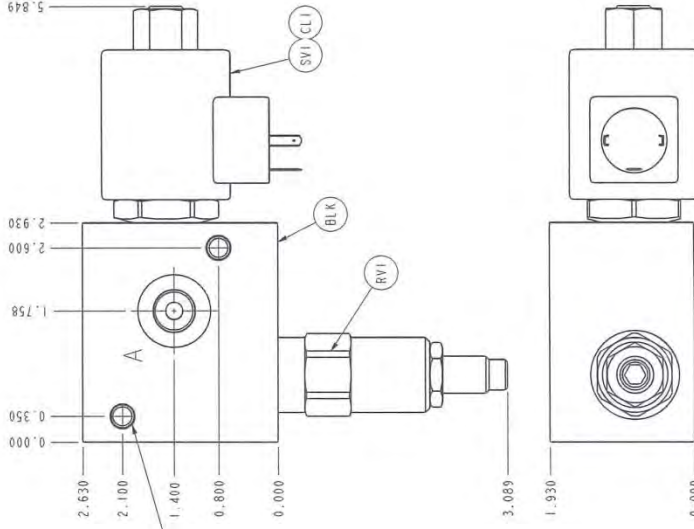
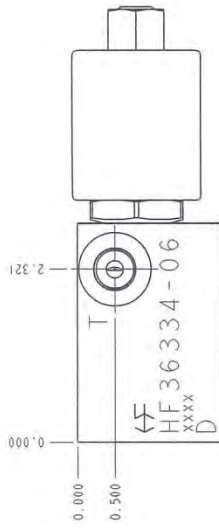

5/16-18UNC-2B X 0.55 DP
2-MTG HOLES

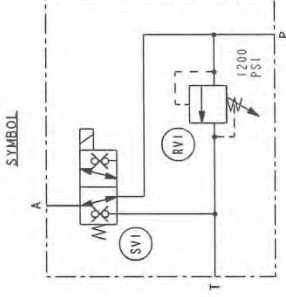
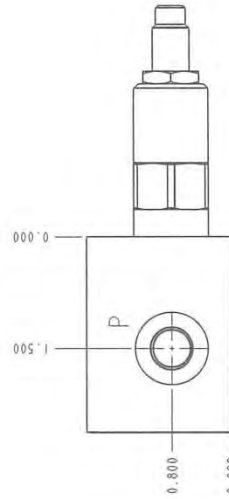

PORTING:
ALL PORTS ARE SAE 06

HYDRAFORCE®
 COMBINATION VALVE 5954707
PROGRAMMABLE CONTROL
 DRAWING NUMBER: HF 36334-06
 SHEET 1 OF 1
 REV 02/14
 DATE 03/02/04

PAIDWEST
HYDRAULICS INC.
 www.paidwest.ca
 1476 Wellington Avenue
 Winnipeg, Manitoba R3E 0K5
 Tel: (204) 783-2277
 Fax: (204) 783-8416

ITEM	QTY	MODEL NUMBER / DESC.
SVI	1	SV38-38-D-N-00
RVI	1	RV08-20A-D-N-33/12
GLI	1	COIL 6356024
NOT SHOWN	1	PLUG 6108080
BLK	1	BLOCK 7182320

UNIT: INCH
DIMENSIONS UNLESS OTHERWISE SPECIFIED

SCALE
 1 : 1
 DO NOT SCALE
 DRAWING
 THIRD ANGLE
 PROJECTION

THIS DRAWING IS THE PROPERTY OF HYDRAFORCE
 AND IS LOANED TO YOU FOR YOUR INFORMATION ONLY.
 IT IS NOT TO BE REPRODUCED OR USED IN ANY MANNER
 WITHOUT THE WRITTEN PERMISSION OF HYDRAFORCE.



Air Hydraulic Pumps Instruction Manual

MODELS: PA1500



This is the safety alert symbol. It is used to alert you to potential personal injury hazards. Obey all safety messages that follow this symbol to avoid possible injury or death.

Maximum Operating Pressure 10,000 PSI

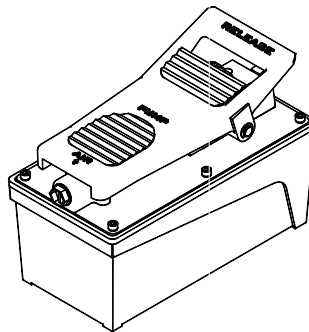

PA1500

Save these instructions. For your safety, read and understand the information contained within. The owner and operator shall have an understanding of this product and safe operating procedures before attempting to use this product. Instructions and safety information shall be conveyed in the operator's native language before use of this product is authorized. Make certain that the operator thoroughly understands the inherent dangers associated with the use and misuse of the product. If any doubt exists as to the safe and proper use of this product as outlined in this factory authorized manual, remove from service immediately.

Inspect before each use. It is recommended that, prior to each use, an inspection be done by qualified personnel and that any missing or damaged parts, decals, warning/ safety labels or signs be replaced with BVA Hydraulics authorized replacement parts only. Any pump that appears to be damaged in any way, is worn, leaking or operates abnormally shall be removed from service immediately until such time as repairs can be made. Any pump that has been or suspected to have been subject to a shock load (a load dropped suddenly, causing the system pressure to exceed 10,000 PSI), shall be removed from service immediately until checked out by a BVA Hydraulics authorized service center. Owners and operators of this equipment shall be aware that the use and subsequent repair of this equipment may require special training and knowledge.

PRODUCT DESCRIPTION

BVA Hydraulics Air Hydraulic Pumps are engineered to meet most Industrial Standards for Performance and Safety. Its unique hydraulic circuit allows quick displacement of hydraulic fluid under no load conditions and easy pumping in loaded conditions. These air actuated pumps supply compressed hydraulic fluid to compatible applications i.e. rams, presses, spreaders, compactors and crimping machines, anywhere that 10,000 PSI of fluid pressure is needed. Special skill, knowledge and training may be required for a specific task and the product may not be suitable for all the jobs described above. Unsuitable applications would include applications that call for a device to move, level or support persons, animals, hazardous materials, mobile homes/ dwellings in general, mirrors and/or plate glass, and/or to connect/secure hatches, components, etc. between bulkheads. The user must ultimately make the decision regarding suitability of the product for any given task and assume the responsibility of safety for himself or herself and others in the work area.

⚠ WARNING: To reduce the risk of personal injury and/or property damage, ensure that the rated working pressure of each pressurized attachment be equal to or greater than the rated working pressure developed by the hydraulic pump.

⚠ Always check connections before using. Alteration of these products is strictly prohibited. Use only those adapters and attachments provided and approved by the manufacturer.

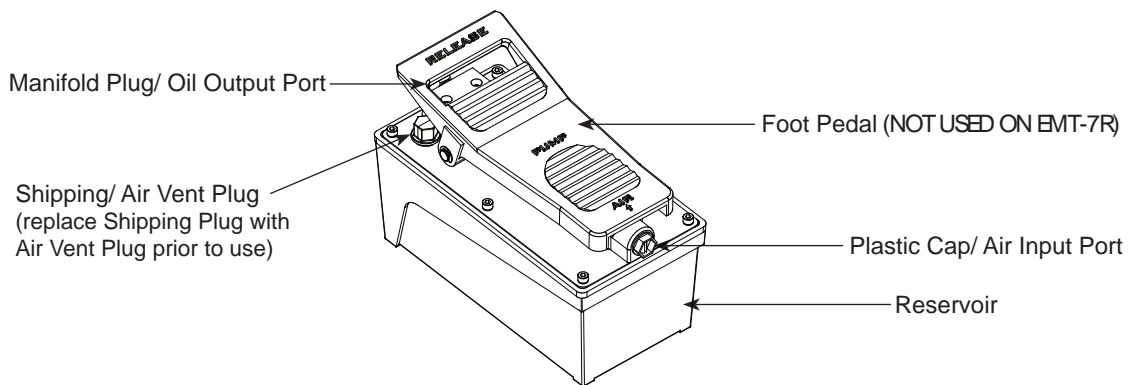

Figure 3 - Models PA1500, Components (PA1500 shown)

SPECIFICATIONS

Model Number	Usable Oil Capacity (in ³)	Rated Pressure (psi)	Output Flow Rate (in ³ /min)		Input Air Pressure (psi)	Output Port Thread (Oil)	Input Port Threads (Air)	Weight (lbs w/fluid)
			No Load	Load				
PA1500	91.5	10,000	66	11	110 - 175	3/8" -18NPTF	1/4" - 18NPT	18.1

⚠ WARNING



- Study, understand, and follow all instructions provided with and on this device before use.
- All WARNING statements must be carefully observed to help prevent personal injury.
- No alteration shall be made to this device.
- Always wear protective gear when operating hydraulic equipment.
- Keep hydraulic equipment away from flames and heat. Hydraulic fluid can ignite and burn. Do not operate if leaks are detected.
- **Crush Hazard.** Keep hands and feet away from loading area. Avoid pinch points or crush points that can be created by the load, cylinder, or any equipment of system.
- To avoid crushing and related injuries: NEVER work on, under or around a lifted load before it is properly supported by appropriate mechanical means. Never rely on hydraulic pressure alone to support load.

- Do not subject the pump and its components to shock loads.
- Use only approved accessories and approved hydraulic fluid.
- Never attach ANY component not authorized by manufacturer.
- Always ensure that the chosen application is stable to work on and around.
- Do not connect to application which can return more oil to the reservoir than the pump reservoir can hold.
- Do not connect pump to hydraulic system powered by another pump.
- This device is not suitable for use as support device! As the system load is lifted, use blocking and cribbing to guard against a falling load.
- All personnel must be clear before lowering load or depressurizing the system.
- Never try to disassemble a hydraulic cylinder, refer repairs to qualified, authorized personnel.

HYDRAULIC HOSES & FLUID TRANSMISSION LINES

HYDRAULIC PUMPS

- The user must be a qualified operator familiar with the correct operation, maintenance, and use of pumps. Lack of knowledge in any of these areas can lead to personal injury.
- Do not exceed rated capacity of the pump or any equipment in the system.
- Never attempt to lift a load weighing more than the capacity of the cylinder.
- Burst hazard exists if hose or connection pressure exceeds rated pressure.
- Inspect pump, cylinder, hoses and connections before each use to prevent unsafe conditions from developing. Do not use if they are damaged, altered or in poor condition. Do not operate the system with bent or damaged coupler or damaged threads.
- Never hold or stand directly in line with any hydraulic connections while pressurizing.
- Use gauge or other load measuring instrument to verify load.
- Never attempt to disconnect hydraulic connections under pressure. Release all line pressure before disconnecting hoses.

- Avoid short runs of straight line tubing. Straight line runs do not provide for expansion and contraction due to pressure and/or temperature changes.
- Reduce stress in tube lines. Long tubing runs should be supported by brackets or clips. Before operating the pump, tighten all hose connections with proper tools. Do not overtighten. Connections should only be tightened securely and leak-free. Overtightening can cause premature thread failure or high pressure fittings to burst.
- Should a hydraulic hose ever rupture, burst or need to be disconnected, immediately shut off the pump and release all pressure. Never attempt to grasp a leaking pressurized hose with your hands. The force of escaping hydraulic fluid can inflict injury.
- Do not subject the hose to potential hazard such as fire, sharp objects, extreme heat or cold, or heavy impact.
- Do not allow the hose to kink, twist, curl, crush, cut or bend so tightly that the fluid flow within the hose is blocked or reduced. Periodically inspect the hose for wear.
- Do not pull, position or move setup by the hose.
- Hose material and coupler seals must be compatible with hydraulic fluid used. Hoses also must not come in contact with corrosive materials such as battery acid, creosote-impregnated objects and wet paint. Never paint a coupler or hose.
- FAILURE TO HEED THESE WARNINGS MAY RESULT IN PERSONAL INJURY AS WELL AS PROPERTY DAMAGE.

BEFORE USE AND SET UP

1. Familiarize yourself with the specifications and illustrations in this owners manual. Know your pump, its limitations and how it operates before attempting to use. Refer to specification chart on page 3 for details of oil port thread size, usable oil capacity, and more. If in doubt, contact BVA Hydraulics Technical Service (888) 332-6419.
2. **For model PA1500:** Replace shipping plug (red color) with air vent plug (black color) before use.
3. **Air Connection:** Remove plastic cap, connect suitable air supply to air input port. Air input port is designed to fit the popular 1/4" NPT air nipple (not included). Ensure that your air source can dedicate 7.8CFM @ 110~175 PSI to each pump operated.
4. **Hydraulic Connection:** Clean all areas around the oil port of pump and cylinder. Inspect all threads and fitting for signs of wear or damage and replace as needed. Clean all hose ends, couplers and union ends. Remove the manifold plug, then connect oil output port to suitable fittings and application/cylinder.

IMPORTANT: Always secure threaded port connections with high grade, non-hardening pipe thread sealant. Teflon tape can be used if only one layer of tape is used and it is applied carefully, two threads back, to prevent the tape from being introduced into hydraulic system, which could cause jamming of precision-fit parts.

 To reduce the risk of personal injury and/or property damage, Hydraulic connections must be securely fastened before building pressure in the system. Release all system pressure before loosening any hydraulic connection in the system.

OPERATION

 Always monitor pressure, load or position using suitable equipment. Pressure may be monitored by means of an optional manifold and gauge. Load may be monitored by means of a load cell and digital indicator. Correct application position can only be determined by the operator of the equipment.

For Models PA1500:

1. To extend the cylinder, depress on the foot pedal until desired position is reached.
2. To hold the cylinder in position, release the foot pedal to the half way detent to deactivate the pump.
3. To retract the cylinder, release foot pedal

Note: Never operate a pump which is disconnected from application. If operate in this condition, the hose and connections will become pressurized. This increases burst hazard. Damage may occur to pump and its components.

MAINTENANCE

Important: Use only good quality hydraulic fluid. **Never** use brake fluid, transmission fluid, turbine oil, motor oil, alcohol, glycerin etc. Use of other than good quality hydraulic oil will void warranty and damage the pump, hose, and application. We recommend Mobil DTE 13M or equivalent.

1. Inspect hoses and connections daily. Replace damaged components immediately.
2. Tighten connections as needed. Use non-hardening pipe thread compound when servicing connections.

Adding Hydraulic Fluid

1. Depressurize and disconnect hydraulic hose from application/ cylinder.
2. For Model PA1500:
With pump in its upright, horizontal position, remove the air vent plug located on the top plate of the reservoir.
3. Use a small funnel to fill the oil to within 3/4" (19mm) of the opening.
4. Wipe up any spilled fluid and reinstall the air vent plug/ reservoir cap.

Changing Hydraulic Fluid

1. For best results, change fluid once a year or every 300 hours of use.
2. Repeat # 2 above, then pour used fluid into a sealable container.
3. Dispose of fluid in accordance with local regulations.
4. Fill with a good quality hydraulic fluid as recommended above. Reinstall air vent plug/ reservoir cap.

Lubrication

When pump is operated on daily basis, the manufacturer recommends installing an inline oiler and air dryer. Use SAE grade oil (5W to 30W).

Storage

1. When not in use, depressurize and disconnect hydraulic pump from application.
2. Wipe clean, thoroughly and store in clean, dry environment. Avoid temperature extremes.
3. For transportation or long storage, replace the air vent plug with shipping plug (for model PA1500).

TROUBLESHOOTING GUIDE

The following information is intended as an aid in determining if problem exists. Pumps should be repaired only by authorized BVA Service Center. For repair service, contact service center in your area.

Symptom	Possible Causes	Corrective Action
Application does not extend, move or respond to pressurized fluid	<ul style="list-style-type: none"> • Overload condition • Loose couplers • Faulty couplers • Pump malfunction • Inadequate air supply 	<ul style="list-style-type: none"> • Remedy overload condition • Tighten couplers • Replace couplers • Contact service center • Ensure air source can dedicate 7.8 CFM @ 110-175 PSI
Application responds to pressurized fluid, but system does not maintain pressure	<ul style="list-style-type: none"> • Overload condition • Pump or valve malfunction • Application/connection leaking 	<ul style="list-style-type: none"> • Remedy overload condition • Contact Service Center • Replace application/connection
Application responds slower than normal	<ul style="list-style-type: none"> • Loose connection or coupler • Restricted hydraulic line or fitting • Application/connection leaking 	<ul style="list-style-type: none"> • Tighten connection or coupler • Clean and replace if damaged • Replace application/connection
Application does not return fluid to pump (i.e. cylinder will not retract)	<ul style="list-style-type: none"> • Malfunctioning coupler, damaged application 	<ul style="list-style-type: none"> • Secure load by other means. Depressurize pump and hose, remove coupler and/or application, then renew or replace
Application does not fully extend (cylinder or spreader)	<ul style="list-style-type: none"> • Reservoir overfilled • Fluid level in pump is low 	<ul style="list-style-type: none"> • Secure load by other means. Depressurize pump and hose, remove application, then drain fluid to proper level • Secure load by other means. Depressurize pump and hose, remove application, then fill fluid to proper level
Poor performance	<ul style="list-style-type: none"> • Fluid level in pump is low 	<ul style="list-style-type: none"> • Ensure proper fluid level



Air Hydraulic Pump Service Parts

MODEL: PA1500

Note: Not all components of the pump are replacement items, but are illustrated as a convenient reference of location and position in the assembly sequence.

PA600-M0
rev 08/07

Parts Illustration

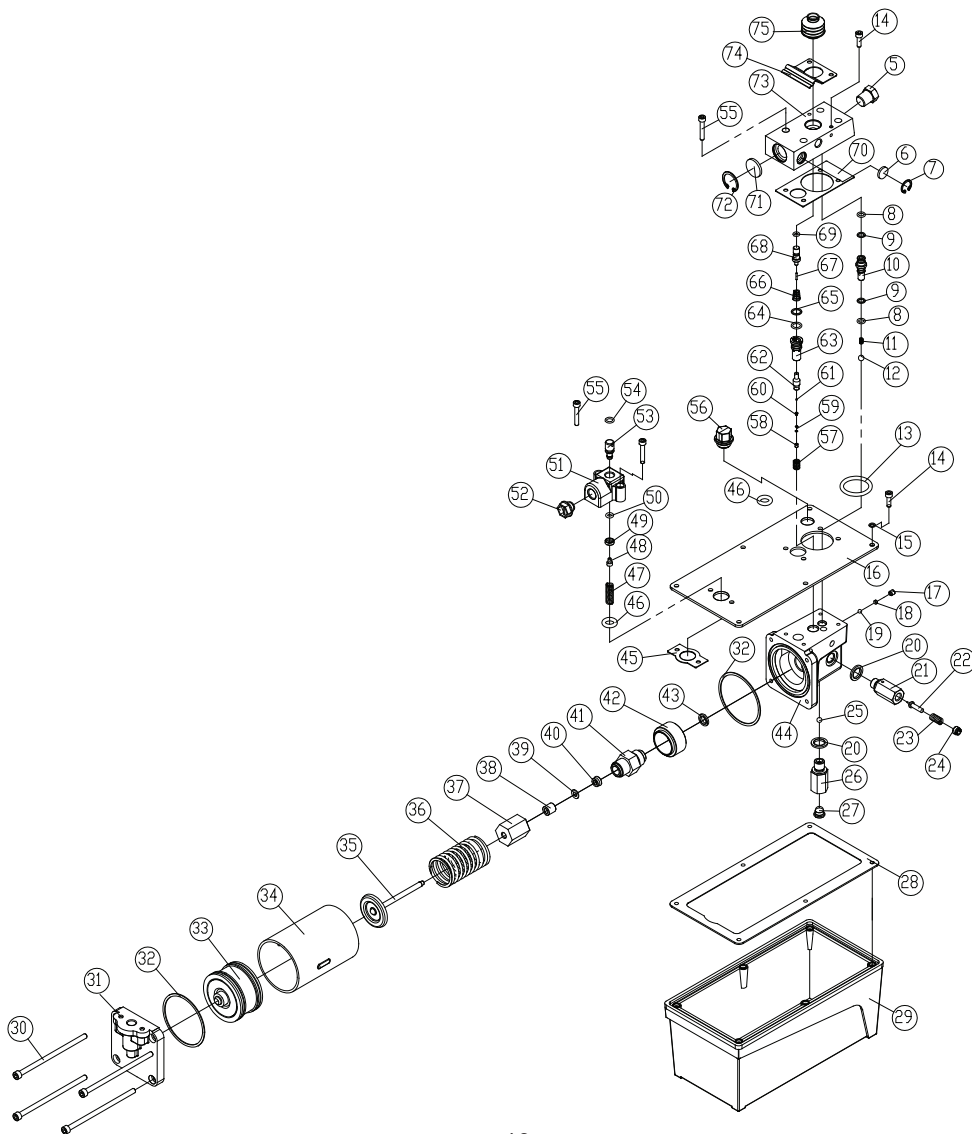



Air Hydraulic Pump Service Parts

MODEL: PA1500

Note: Not all components of the pump are replacement items, but are illustrated as a convenient reference of location and position in the assembly sequence.

PA600-M0
rev 08/07

Parts List

Item	PA1500 Part#	Description	Qty	Item	PA1500 Part#	Description	Qty
5	D05-6-1001-106	Manifold plug (oil output port)	1	39	573-7-0120-105	Back-up ring	1
6	A57-6-3007-105	Noise suppressor	1	40	*	U-cup	1
7	666-5-0160-107	C-clip	1	41	A59-6-1013-105	Pump piston cylinder	1
8	*	O-ring	2	42	A57-6-1016-106	Spacer	1
9	*	Back-up ring	2	43	H18-6-8103-104	Crush washer	1
10	A57-6-4002-201	Oil discharge valve	1	44	A57-6-1001-204	Base, hydraulic unit	1
11	512-2-0043-108	Compression spring	1	45	A57-6-1605-105	Gasket	1
12	601-7-0009-001	Steel ball	1	46	511-7-0140-200	O-ring	2
13	511-7-0410-102	O-ring	1	47	512-2-0092-101	Compression spring	1
14	649-1-0050-055	Allen screw (M5x0.8x15L)	8	48	649-1-0040-007	Allen screw (M4x0.7x0.6L)	1
15	*	Copper washer	6	49	A57-6-5004-109	Air intake cap	1
16	A57-6-1603-202	Top reservoir plate	1	50	511-7-0053-104	O-ring	1
17	644-1-0060-05311	Set screw	1	51	A57-6-5001-103	Air manifold	1
18	503-9-0050-106	Steel ball seat	1	52	A17-6-1105-103	Plastic cap (air)	1
19	601-7-0006-005	Steel ball	1	53	A57-6-5003-107	Air intake valve	1
20	*	Crush washer	2	54	511-7-0080-309	O-ring	1
21	A59-6-1017-102	Pressure relief valve cylinder	1	55	649-1-0050-046	Allen screw (M5x0.8x30L)	6
22	A17-6-1216-102	Pressure relief valve stem	1	56a	A57-3-5007-107	Shipping plug (red)	1
23	512-2-0067-010	Compression spring	1	56b	A57-3-1900-109	Air vent plug (black)	1
24	A17-5-1603-300	Pressure relief valve screw	1	57	512-2-0061-100	Compression spring	1
25	601-7-0008-009	Steel ball	1	58	644-1-0040-204	Lower assy. bolt	1
26	A59-6-1015-108	Oil intake valve	1	59	*	Compression spring	1
27	520-8-0134-101	Filter	1	60	503-9-0035-100	Steel ball seat	1
28	*	Gasket	1	61	601-7-0003-009	Steel ball	1
29	A57-6-1601-107	Oil reservoir	1	62	A57-6-3003-305	Release valve	1
30	649-1-0060-122	Thru bolt, air motor	4	63	A57-6-3004-307	Release valve guide	1
31	A57-6-1002-105	End plate, air motor	1	64	*	O-ring	1
32	A17-6-2105-108	Gasket	2	65	*	Back-up ring	1
33	A17-4-2100-500	Air motor piston	1	66	552-2-0010-105	Compression spring	1
34	A57-6-1003-107	Cylinder, air motor piston	1	67	*	Release valve pin	1
35	A57-3-1011-108	Pump piston	1	68	A57-6-3001-112	Release valve cap	1
36	512-2-0410-017	Compression spring	1	69	*	O-ring	1
37	A57-6-1014-102	Pump piston guide	1	70	*	Gasket	1
38	A57-6-2023-108	Bushing	1	71	A17-6-1002-103	Noise suppressor	1
				72	666-5-0250-108	C-clip	1
				73	A57-6-6004-104	Oil manifold	1
				74	A57-6-5101-107	Detent spring	1
				75	A57-6-6005-106	Dust boot	1
				(*)	A57-3-9901-101	Seal kit	-

(*) indicated items included in, and available only as part of Seal Kit

LIFETIME LIMITED WARRANTY

BVA Hydraulics®, represented in the United States by SFA Companies ["SFA"] warrants this product to be free from defects in material and workmanship for the life of the product as long as the original purchaser owns the product. The warranty is non-transferable and is subject to the terms, exclusions, and limitations described below:

- Damaged components, including but not limited to bent rams, dented or crushed cylinder walls, broken welds or couplers as well as worn out seals, o-rings and springs are the result of misuse and not covered by warranty and BVA Hydraulics will not provide any warranty credit for such damaged components.
- This warranty does not cover ordinary wear and tear, overloading, alterations (including repairs or attempted repairs not performed by BVA Hydraulics or one of its authorized personnel), improper fluid use, or use of the product in any manner for which the product was not intended or the use of which is not in accordance with the instructions or warnings provided with the product.
- In the unlikely event that a BVA Hydraulics product fails due to material defect in workmanship, you may contact SFA for disposition. In such cases, the customer's sole and exclusive remedy for any breach or alleged breach of warranty is limited to the repair or replacement of the defective product.
- Under no circumstances is BVA Hydraulics liable for any consequential or incidental damage or loss whatsoever.
- THIS WARRANTY IS LIMITED TO NEW PRODUCTS SOLD THROUGH AUTHORIZED DISTRIBUTORS AND OTHER CHANNELS DESIGNATED BY BVA HYDRAULICS. NO AGENT, EMPLOYEE OR OTHER REPRESENTATIVE OF BVA HYDRAULICS IS AUTHORIZED TO MODIFY THIS WARRANTY.
- THE FOREGOING IS EXCLUSIVE AND IS IN LIEU OF ALL OTHER EXPRESS AND IMPLIED WARRANTIES, INCLUDING BUT NOT LIMITED TO THE IMPLIED WARRANTIES OF MERCHANTABILITY AND FOR A FITNESS FOR A PARTICULAR PURPOSE.
- Components not manufactured by BVA Hydraulics including certain motor systems, gasoline engines, and others are not covered by this warranty and instead are covered by the manufacturer's separate manufacturer's warranty provided in the package.
- BVA Hydraulics' liability in all cases is limited to, and will not exceed the purchase price paid for the product.



390 Eagle Drive, Winnipeg, MB, R3C 2E6
Ph# 800-665-8089, Fax# 204-779-7796
email: sales@empire-machinery.com
www.empire-machinery.com



Single Acting, Hollow Hole Cylinders Service Parts

MODELS: HC1202T

Note: Not all components of the pump are replacement items, but are illustrated as a convenient reference of location and position in the assembly sequence.

Item	Part Number for Model:		Description	Qty
	HC1202T			
1	H32-6-2305-100		Collar Protective Cap	1
2	*		O-ring	1
3	H32-6-1821-103		Upper Bearing	1
4	512-2-0470-107		Return Spring	1
5	*		Back-up Ring	1
6	N/A		O-ring	1
	*		U-cup	1
7	N/A		Ram	1
8	*		O-ring	1
9	*		Back-up Ring	1
10	N/A		O-ring	1
	*		U-cup	1
11	N/A		Cylinder	1
12	*		O-ring	1
13	*		Back-up Ring	1
14	N/A		Center Tube	1
15	666-5-0300-107		C-clip	1
16	434-4-3201-108		Female Coupler	1
17	H20-6-6008-102		Bushing	1
18	H32-6-1122-107		Bearing	1
19	H32-6-1121-105		Bearing	1
(*)	H32-3-9905-101		Seal Kit	-

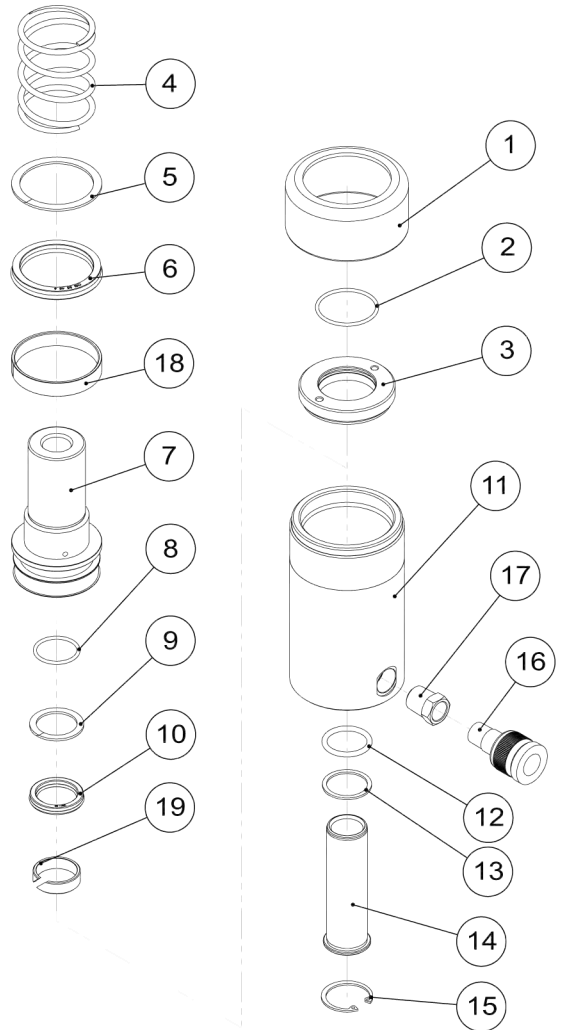

(*) - indicates items included in, and available only as part of Seal Kit
N/A - part is not available as replacement



Air Hydraulic Pumps Instruction Manual

MODELS: PA1500



This is the safety alert symbol. It is used to alert you to potential personal injury hazards. Obey all safety messages that follow this symbol to avoid possible injury or death.

Maximum Operating Pressure 10,000 PSI

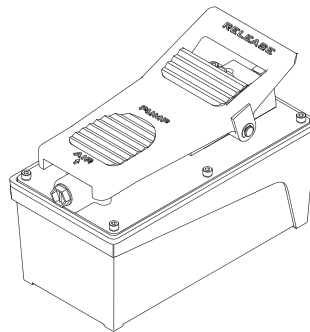

PA1500

Save these instructions. For your safety, read and understand the information contained within. The owner and operator shall have an understanding of this product and safe operating procedures before attempting to use this product. Instructions and safety information shall be conveyed in the operator's native language before use of this product is authorized. Make certain that the operator thoroughly understands the inherent dangers associated with the use and misuse of the product. If any doubt exists as to the safe and proper use of this product as outlined in this factory authorized manual, remove from service immediately.

Inspect before each use. It is recommended that, prior to each use, an inspection be done by qualified personnel and that any missing or damaged parts, decals, warning/ safety labels or signs be replaced with BVA Hydraulics authorized replacement parts only. Any pump that appears to be damaged in any way, is worn, leaking or operates abnormally shall be removed from service immediately until such time as repairs can be made. Any pump that has been or suspected to have been subject to a shock load (a load dropped suddenly, causing the system pressure to exceed 10,000 PSI), shall be removed from service immediately until checked out by a BVA Hydraulics authorized service center. Owners and operators of this equipment shall be aware that the use and subsequent repair of this equipment may require special training and knowledge.

PRODUCT DESCRIPTION

BVA Hydraulics Air Hydraulic Pumps are engineered to meet most Industrial Standards for Performance and Safety. Its unique hydraulic circuit allows quick displacement of hydraulic fluid under no load conditions and easy pumping in loaded conditions. These air actuated pumps supply compressed hydraulic fluid to compatible applications i.e. rams, presses, spreaders, compactors and crimping machines, anywhere that 10,000 PSI of fluid pressure is needed. Special skill, knowledge and training may be required for a specific task and the product may not be suitable for all the jobs described above. Unsuitable applications would include applications that call for a device to move, level or support persons, animals, hazardous materials, mobile homes/ dwellings in general, mirrors and/or plate glass, and/or to connect/secure hatches, components, etc. between bulkheads. The user must ultimately make the decision regarding suitability of the product for any given task and assume the responsibility of safety for himself or herself and others in the work area.

⚠ WARNING: To reduce the risk of personal injury and/or property damage, ensure that the rated working pressure of each pressurized attachment be equal to or greater than the rated working pressure developed by the hydraulic pump.

⚠ Always check connections before using. Alteration of these products is strictly prohibited. Use only those adapters and attachments provided and approved by the manufacturer.

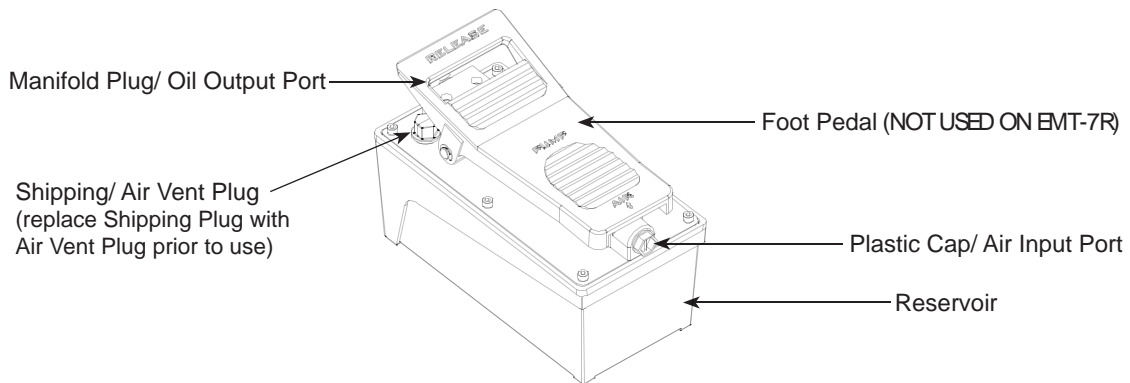

Figure 3 - Models PA1500, Components (PA1500 shown)

SPECIFICATIONS

Model Number	Usable Oil Capacity (in ³)	Rated Pressure (psi)	Output Flow Rate (in ³ /min)		Input Air Pressure (psi)	Output Port Thread (Oil)	Input Port Threads (Air)	Weight (lbs w/fluid)
			No Load	Load				
PA1500	91.5	10,000	66	11	110 - 175	3/8" -18NPTF	1/4" - 18NPT	18.1

⚠ WARNING



- Study, understand, and follow all instructions provided with and on this device before use.
- All WARNING statements must be carefully observed to help prevent personal injury.
- No alteration shall be made to this device.
- Always wear protective gear when operating hydraulic equipment.
- Keep hydraulic equipment away from flames and heat. Hydraulic fluid can ignite and burn. Do not operate if leaks are detected.
- **Crush Hazard.** Keep hands and feet away from loading area. Avoid pinch points or crush points that can be created by the load, cylinder, or any equipment of system.
- To avoid crushing and related injuries: NEVER work on, under or around a lifted load before it is properly supported by appropriate mechanical means. Never rely on hydraulic pressure alone to support load.

- Do not subject the pump and its components to shock loads.
- Use only approved accessories and approved hydraulic fluid.
- Never attach ANY component not authorized by manufacturer.
- Always ensure that the chosen application is stable to work on and around.
- Do not connect to application which can return more oil to the reservoir than the pump reservoir can hold.
- Do not connect pump to hydraulic system powered by another pump.
- This device is not suitable for use as support device! As the system load is lifted, use blocking and cribbing to guard against a falling load.
- All personnel must be clear before lowering load or depressurizing the system.
- Never try to disassemble a hydraulic cylinder, refer repairs to qualified, authorized personnel.

HYDRAULIC HOSES & FLUID TRANSMISSION LINES

HYDRAULIC PUMPS

- The user must be a qualified operator familiar with the correct operation, maintenance, and use of pumps. Lack of knowledge in any of these areas can lead to personal injury.
- Do not exceed rated capacity of the pump or any equipment in the system.
- Never attempt to lift a load weighing more than the capacity of the cylinder.
- Burst hazard exists if hose or connection pressure exceeds rated pressure.
- Inspect pump, cylinder, hoses and connections before each use to prevent unsafe conditions from developing. Do not use if they are damaged, altered or in poor condition. Do not operate the system with bent or damaged coupler or damaged threads.
- Never hold or stand directly in line with any hydraulic connections while pressurizing.
- Use gauge or other load measuring instrument to verify load.
- Never attempt to disconnect hydraulic connections under pressure. Release all line pressure before disconnecting hoses.

- Avoid short runs of straight line tubing. Straight line runs do not provide for expansion and contraction due to pressure and/or temperature changes.
- Reduce stress in tube lines. Long tubing runs should be supported by brackets or clips. Before operating the pump, tighten all hose connections with proper tools. Do not overtighten. Connections should only be tightened securely and leak-free. Overtightening can cause premature thread failure or high pressure fittings to burst.
- Should a hydraulic hose ever rupture, burst or need to be disconnected, immediately shut off the pump and release all pressure. Never attempt to grasp a leaking pressurized hose with your hands. The force of escaping hydraulic fluid can inflict injury.
- Do not subject the hose to potential hazard such as fire, sharp objects, extreme heat or cold, or heavy impact.
- Do not allow the hose to kink, twist, curl, crush, cut or bend so tightly that the fluid flow within the hose is blocked or reduced. Periodically inspect the hose for wear.
- Do not pull, position or move setup by the hose.
- Hose material and coupler seals must be compatible with hydraulic fluid used. Hoses also must not come in contact with corrosive materials such as battery acid, creosote-impregnated objects and wet paint. Never paint a coupler or hose.
- FAILURE TO HEED THESE WARNINGS MAY RESULT IN PERSONAL INJURY AS WELL AS PROPERTY DAMAGE.

BEFORE USE AND SET UP

1. Familiarize yourself with the specifications and illustrations in this owners manual. Know your pump, its limitations and how it operates before attempting to use. Refer to specification chart on page 3 for details of oil port thread size, usable oil capacity, and more. If in doubt, contact BVA Hydraulics Technical Service (888) 332-6419.
2. **For model PA1500:** Replace shipping plug (red color) with air vent plug (black color) before use.
3. **Air Connection:** Remove plastic cap, connect suitable air supply to air input port. Air input port is designed to fit the popular 1/4" NPT air nipple (not included). Ensure that your air source can dedicate 7.8CFM @ 110~175 PSI to each pump operated.
4. **Hydraulic Connection:** Clean all areas around the oil port of pump and cylinder. Inspect all threads and fitting for signs of wear or damage and replace as needed. Clean all hose ends, couplers and union ends. Remove the manifold plug, then connect oil output port to suitable fittings and application/cylinder.

IMPORTANT: Always secure threaded port connections with high grade, non-hardening pipe thread sealant. Teflon tape can be used if only one layer of tape is used and it is applied carefully, two threads back, to prevent the tape from being introduced into hydraulic system, which could cause jamming of precision-fit parts.

 To reduce the risk of personal injury and/or property damage, Hydraulic connections must be securely fastened before building pressure in the system. Release all system pressure before loosening any hydraulic connection in the system.

OPERATION

 Always monitor pressure, load or position using suitable equipment. Pressure may be monitored by means of an optional manifold and gauge. Load may be monitored by means of a load cell and digital indicator. Correct application position can only be determined by the operator of the equipment.

For Models PA1500:

1. To extend the cylinder, depress on the foot pedal until desired position is reached.
2. To hold the cylinder in position, release the foot pedal to the half way detent to deactivate the pump.
3. To retract the cylinder, release foot pedal

Note: Never operate a pump which is disconnected from application. If operate in this condition, the hose and connections will become pressurized. This increases burst hazard. Damage may occur to pump and its components.

MAINTENANCE

Important: Use only good quality hydraulic fluid. **Never** use brake fluid, transmission fluid, turbine oil, motor oil, alcohol, glycerin etc. Use of other than good quality hydraulic oil will void warranty and damage the pump, hose, and application. We recommend Mobil DTE 13M or equivalent.

1. Inspect hoses and connections daily. Replace damaged components immediately.
2. Tighten connections as needed. Use non-hardening pipe thread compound when servicing connections.

Adding Hydraulic Fluid

1. Depressurize and disconnect hydraulic hose from application/ cylinder.
2. For Model PA1500:
With pump in its upright, horizontal position, remove the air vent plug located on the top plate of the reservoir.
3. Use a small funnel to fill the oil to within 3/4" (19mm) of the opening.
4. Wipe up any spilled fluid and reinstall the air vent plug/ reservoir cap.

Changing Hydraulic Fluid

1. For best results, change fluid once a year or every 300 hours of use.
2. Repeat # 2 above, then pour used fluid into a sealable container.
3. Dispose of fluid in accordance with local regulations.
4. Fill with a good quality hydraulic fluid as recommended above. Reinstall air vent plug/ reservoir cap.

Lubrication

When pump is operated on daily basis, the manufacturer recommends installing an inline oiler and air dryer. Use SAE grade oil (5W to 30W).

Storage

1. When not in use, depressurize and disconnect hydraulic pump from application.
2. Wipe clean, thoroughly and store in clean, dry environment. Avoid temperature extremes.
3. For transportation or long storage, replace the air vent plug with shipping plug (for model PA1500).

TROUBLESHOOTING GUIDE

The following information is intended as an aid in determining if problem exists. Pumps should be repaired only by authorized BVA Service Center. For repair service, contact service center in your area.

Symptom	Possible Causes	Corrective Action
Application does not extend, move or respond to pressurized fluid	<ul style="list-style-type: none"> • Overload condition • Loose couplers • Faulty couplers • Pump malfunction • Inadequate air supply 	<ul style="list-style-type: none"> • Remedy overload condition • Tighten couplers • Replace couplers • Contact service center • Ensure air source can dedicate 7.8 CFM @ 110-175 PSI
Application responds to pressurized fluid, but system does not maintain pressure	<ul style="list-style-type: none"> • Overload condition • Pump or valve malfunction • Application/connection leaking 	<ul style="list-style-type: none"> • Remedy overload condition • Contact Service Center • Replace application/connection
Application responds slower than normal	<ul style="list-style-type: none"> • Loose connection or coupler • Restricted hydraulic line or fitting • Application/connection leaking 	<ul style="list-style-type: none"> • Tighten connection or coupler • Clean and replace if damaged • Replace application/connection
Application does not return fluid to pump (i.e. cylinder will not retract)	<ul style="list-style-type: none"> • Malfunctioning coupler, damaged application 	<ul style="list-style-type: none"> • Secure load by other means. Depressurize pump and hose, remove coupler and/or application, then renew or replace
Application does not fully extend (cylinder or spreader)	<ul style="list-style-type: none"> • Reservoir overfilled • Fluid level in pump is low 	<ul style="list-style-type: none"> • Secure load by other means. Depressurize pump and hose, remove application, then drain fluid to proper level • Secure load by other means. Depressurize pump and hose, remove application, then fill fluid to proper level
Poor performance	<ul style="list-style-type: none"> • Fluid level in pump is low 	<ul style="list-style-type: none"> • Ensure proper fluid level



Air Hydraulic Pump Service Parts

MODEL: PA1500

Note: Not all components of the pump are replacement items, but are illustrated as a convenient reference of location and position in the assembly sequence.

PA600-M0
rev 08/07

Parts Illustration

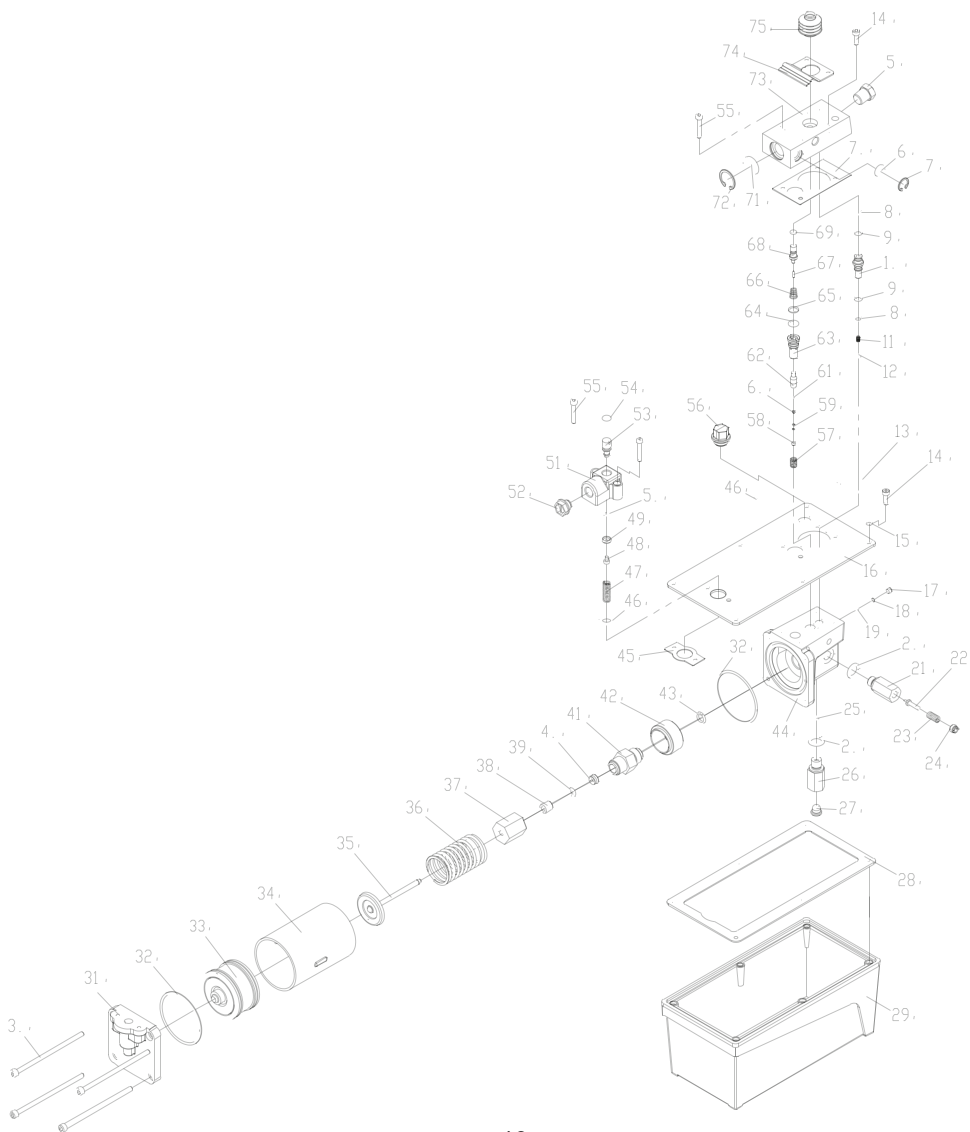



Air Hydraulic Pump Service Parts

MODEL: PA1500

Note: Not all components of the pump are replacement items, but are illustrated as a convenient reference of location and position in the assembly sequence.

PA600-M0
rev 08/07

Parts List

Item	PA1500 Part#	Description	Qty
5	D05-6-1001-106	Manifold plug (oil output port)	1
6	A57-6-3007-105	Noise suppressor	1
7	666-5-0160-107	C-clip	1
8	*	O-ring	2
9	*	Back-up ring	2
10	A57-6-4002-201	Oil discharge valve	1
11	512-2-0043-108	Compression spring	1
12	601-7-0009-001	Steel ball	1
13	511-7-0410-102	O-ring	1
14	649-1-0050-055	Allen screw (M5x0.8x15L)	8
15	*	Copper washer	6
16	A57-6-1603-202	Top reservoir plate	1
17	644-1-0060-05311	Set screw	1
18	503-9-0050-106	Steel ball seat	1
19	601-7-0006-005	Steel ball	1
20	*	Crush washer	2
21	A59-6-1017-102	Pressure relief valve cylinder	1
22	A17-6-1216-102	Pressure relief valve stem	1
23	512-2-0067-010	Compression spring	1
24	A17-5-1603-300	Pressure relief valve screw	1
25	601-7-0008-009	Steel ball	1
26	A59-6-1015-108	Oil intake valve	1
27	520-8-0134-101	Filter	1
28	*	Gasket	1
29	A57-6-1601-107	Oil reservoir	1
30	649-1-0060-122	Thru bolt, air motor	4
31	A57-6-1002-105	End plate, air motor	1
32	A17-6-2105-108	Gasket	2
33	A17-4-2100-500	Air motor piston	1
34	A57-6-1003-107	Cylinder, air motor piston	1
35	A57-3-1011-108	Pump piston	1
36	512-2-0410-017	Compression spring	1
37	A57-6-1014-102	Pump piston guide	1
38	A57-6-2023-108	Bushing	1

Item	PA1500 Part#	Description	Qty
39	573-7-0120-105	Back-up ring	1
40	*	U-cup	1
41	A59-6-1013-105	Pump piston cylinder	1
42	A57-6-1016-106	Spacer	1
43	H18-6-8103-104	Crush washer	1
44	A57-6-1001-204	Base, hydraulic unit	1
45	A57-6-1605-105	Gasket	1
46	511-7-0140-200	O-ring	2
47	512-2-0092-101	Compression spring	1
48	649-1-0040-007	Allen screw (M4x0.7x0.6L)	1
49	A57-6-5004-109	Air intake cap	1
50	511-7-0053-104	O-ring	1
51	A57-6-5001-103	Air manifold	1
52	A17-6-1105-103	Plastic cap (air)	1
53	A57-6-5003-107	Air intake valve	1
54	511-7-0080-309	O-ring	1
55	649-1-0050-046	Allen screw (M5x0.8x30L)	6
56a	A57-3-5007-107	Shipping plug (red)	1
56b	A57-3-1900-109	Air vent plug (black)	1
57	512-2-0061-100	Compression spring	1
58	644-1-0040-204	Lower assy. bolt	1
59	*	Compression spring	1
60	503-9-0035-100	Steel ball seat	1
61	601-7-0003-009	Steel ball	1
62	A57-6-3003-305	Release valve	1
63	A57-6-3004-307	Release valve guide	1
64	*	O-ring	1
65	*	Back-up ring	1
66	552-2-0010-105	Compression spring	1
67	*	Release valve pin	1
68	A57-6-3001-112	Release valve cap	1
69	*	O-ring	1
70	*	Gasket	1
71	A17-6-1002-103	Noise suppressor	1
72	666-5-0250-108	C-clip	1
73	A57-6-6004-104	Oil manifold	1
74	A57-6-5101-107	Detent spring	1
75	A57-6-6005-106	Dust boot	1
(*)	A57-3-9901-101	Seal kit	-

(*) indicated items included in, and available only as part of Seal Kit

LIFETIME LIMITED WARRANTY

BVA Hydraulics®, represented in the United States by SFA Companies ["SFA"] warrants this product to be free from defects in material and workmanship for the life of the product as long as the original purchaser owns the product. The warranty is non-transferable and is subject to the terms, exclusions, and limitations described below:

- Damaged components, including but not limited to bent rams, dented or crushed cylinder walls, broken welds or couplers as well as worn out seals, o-rings and springs are the result of misuse and not covered by warranty and BVA Hydraulics will not provide any warranty credit for such damaged components.
- This warranty does not cover ordinary wear and tear, overloading, alterations (including repairs or attempted repairs not performed by BVA Hydraulics or one of its authorized personnel), improper fluid use, or use of the product in any manner for which the product was not intended or the use of which is not in accordance with the instructions or warnings provided with the product.
- In the unlikely event that a BVA Hydraulics product fails due to material defect in workmanship, you may contact SFA for disposition. In such cases, the customer's sole and exclusive remedy for any breach or alleged breach of warranty is limited to the repair or replacement of the defective product.
- Under no circumstances is BVA Hydraulics liable for any consequential or incidental damage or loss whatsoever.
- THIS WARRANTY IS LIMITED TO NEW PRODUCTS SOLD THROUGH AUTHORIZED DISTRIBUTORS AND OTHER CHANNELS DESIGNATED BY BVA HYDRAULICS. NO AGENT, EMPLOYEE OR OTHER REPRESENTATIVE OF BVA HYDRAULICS IS AUTHORIZED TO MODIFY THIS WARRANTY.
- THE FOREGOING IS EXCLUSIVE AND IS IN LIEU OF ALL OTHER EXPRESS AND IMPLIED WARRANTIES, INCLUDING BUT NOT LIMITED TO THE IMPLIED WARRANTIES OF MERCHANTABILITY AND FOR A FITNESS FOR A PARTICULAR PURPOSE.
- Components not manufactured by BVA Hydraulics including certain motor systems, gasoline engines, and others are not covered by this warranty and instead are covered by the manufacturer's separate manufacturer's warranty provided in the package.
- BVA Hydraulics' liability in all cases is limited to, and will not exceed the purchase price paid for the product.



390 Eagle Drive, Winnipeg, MB, R3C 2E6
Ph# 800-665-8089, Fax# 204-779-7796
email: sales@empire-machinery.com
www.empire-machinery.com

Single Acting, Hollow Hole Cylinders Service Parts

MODELS: HC1202T

Note: Not all components of the pump are replacement items, but are illustrated as a convenient reference of location and position in the assembly sequence.

Item	Part Number for Model:		Description	Qty
	HC1202T			
1	H32-6-2305-100		Collar Protective Cap	1
2	*		O-ring	1
3	H32-6-1821-103		Upper Bearing	1
4	512-2-0470-107		Return Spring	1
5	*		Back-up Ring	1
6	N/A		O-ring	1
	*		U-cup	1
7	N/A		Ram	1
8	*		O-ring	1
9	*		Back-up Ring	1
10	N/A		O-ring	1
	*		U-cup	1
11	N/A		Cylinder	1
12	*		O-ring	1
13	*		Back-up Ring	1
14	N/A		Center Tube	1
15	666-5-0300-107		C-clip	1
16	434-4-3201-108		Female Coupler	1
17	H20-6-6008-102		Bushing	1
18	H32-6-1122-107		Bearing	1
19	H32-6-1121-105		Bearing	1
(*)	H32-3-9905-101		Seal Kit	-

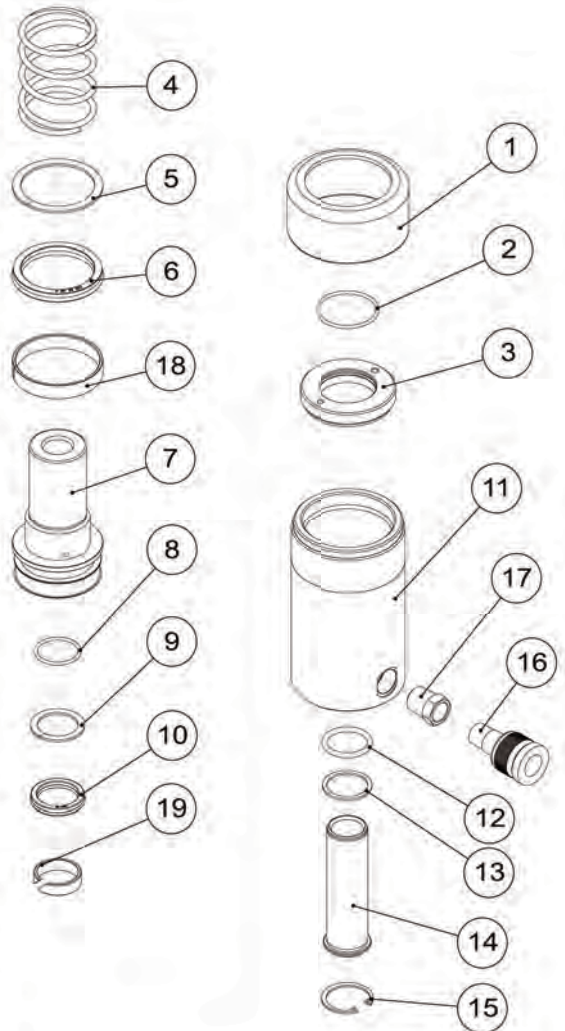

(*) - indicates items included in, and available only as part of Seal Kit
N/A - part is not available as replacement