

flagler

Designers and Manufacturers of Sheet Metal Roll Forming Machinery

20 Ga. Standard Pittsburgh Machine

Operating Instructions and Parts List

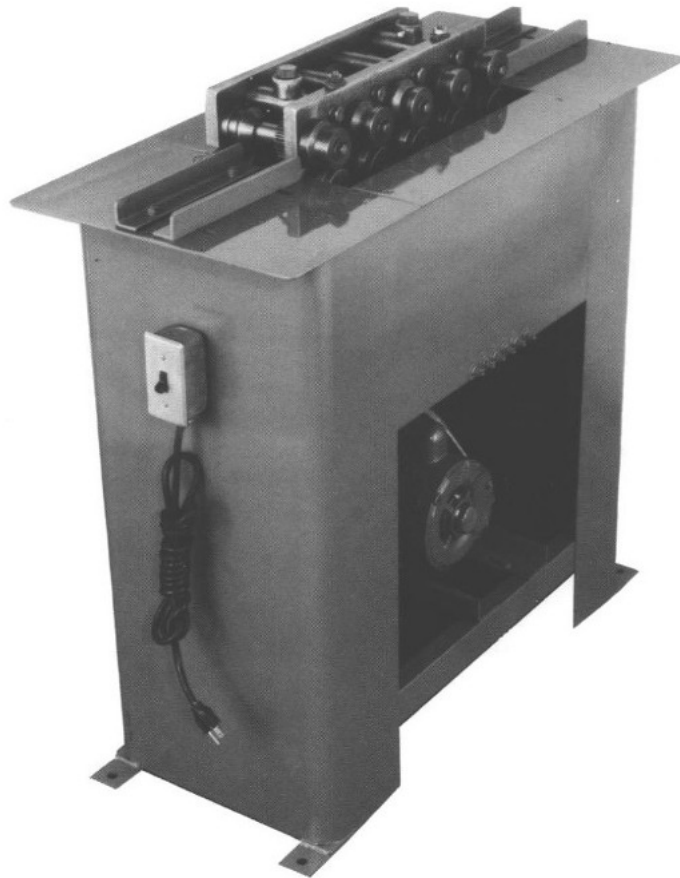

Operating Instructions

Place the material (20 Ga. max) against the feed gauge. Slide the material into the forming head. Be sure that the material remains against the gauge the entire time.

Note: This machine will handle sheets 7" and longer. If shorter pieces are required, the sheet must be cut and notched after running through the machine.

MACHINE COVER MUST BE IN PLACE WHEN IN OPERATION

Hold Down Adjustments

To adjust:

1. Remove the top cover, loosen square head set screws on the 5/8" hold down bolts and the acorn nuts on the 3/8" hold down studs.
2. Tighten the 5/8" hold down bolts and the 3/8" stud jam nuts until the spring washers are flat, then back off approximately 3/4 of a turn on each (this setting will usually give proper adjustment for all thickness' of material capable for this machine).
3. If the material slips or sticks, the following applies:
Pittsburgh Lock Tighten the 5/8" hold down bolts equally until the condition is overcome.
Auxiliary Rolls Tighten the 3/8" stud jam nuts equally until the condition is overcome.
4. Tighten the square head set screws and acorn nuts. Replace cover.

For Pittsburgh Locks

If a wider or narrower hammer-over edge is desired, the feed gauge can be moved to give the desired width. When moving this gauge, be sure to move both ends the same distance, keeping the gauge parallel to the front edge of the top plate of the forming head.

The take-off gauge on the exit end of the machine should be flush against the metal as it emerges from the rolls.

It is very important that long sheets be fed into the machine flat and against the feed gauge from the start.

IMPORTANT: If proper care is taken, the small knife edge roll (opening roll) that holds the pocket of the Pittsburgh Lock open will not break. If burrs and twists from snip cuts are not flattened out, they may strike against the opening roll causing it to break. Also, be sure to keep the opening roll free from galvanized build-up.

Lubrication

Six zerk fittings are located on the upper side panel of the auxiliary side of the machine. These are for lubrication of the bearings on the hi-speed pinion gears. Apply grease (lithium 2 or equivalent) at least once a month. The slow speed shafts do not require bearing lubrication. If required, use open gear grease on the gears. Use Flagler Lubaroll Degalvanizer on the forming rolls and opening roll. If the machine is used outdoors, and oil or grease film will prevent surfaces from rusting.

Installing auxiliary rolls

Double Seam (Acme) or Right Angle Flange Rolls:

1. Disconnect power.
2. Remove top cover.
3. Remove the top-side plate on the auxiliary side of the machine. This will expose the extended shafts on which the rolls are to be mounted.
4. Select the first pair of rolls, which are marked "T-1" and "B-1" and slip them on the shafts at the feed end of the machine, placing "T-1" on the upper shaft and "B-1" on the lower shaft. Repeat this procedure with rolls T & B 2, 3, 4, & 5 until all rolls have been mounted. All rolls marked "T" should be on top shafts

Important: Disconnect Power Before Removing Covers for Any Reason

and "B" rolls on the bottom shafts, in numerical order, reading from left to right, facing the shafts. THE NUMBERED SIDES MUST FACE OUTWARD, OR TOWARDS THE OPERATOR.

5. Fasten the roll to the shaft with the bolts and special washers provided.
6. Mount the feed gauge on the entrance end of the machine using the slotted holes provided in the top plate. See the drawing and chart for the proper setup dimensions. The angle gauge on the exit end should be flush against the metal as it emerges from the rolls
7. Replace the top side plate and machine cover.
8. Reconnect power
9. Hold material against the feed gauge and feed into the machine
10. Adjust accordingly

Drive Cleat Rolls:

1. Proceed as instructed above, but leave the "T-2" loose. This roll is called a floater and it centers itself and should not be held in place with cap screws. However, Woodruff keys are used in all cases.
2. Laying a straight edge on the outside of the gauge and measuring 3/4" to the faces of the rolls sets the Drive Cleat feed gauge. (See drawing).
3. The slide plate adjustment is made by trial and error due to the difference of physical qualities of various materials. If the finished cleat bows up, adjust slide "down". If the material bows down, adjust slide "up". Very little movement is needed for proper adjustment.
4. IMPORTANT: Be sure to cut your material a full 2 1/8" wide to insure a perfect cleat.

Gauge Setup Chart

	Pittsburgh	Double Seam	R.A.F
Material Allowance (approx.)	1"	1"	To Suit
20-22 Gauge Setup (approx.)	2 3/8"	1 1/4"	1 1/16"
For Drive Cleat rolls, shear the material to 2 1/8" wide, set the feed gauge 3/4" from a straight edge placed against the face of the rolls.			

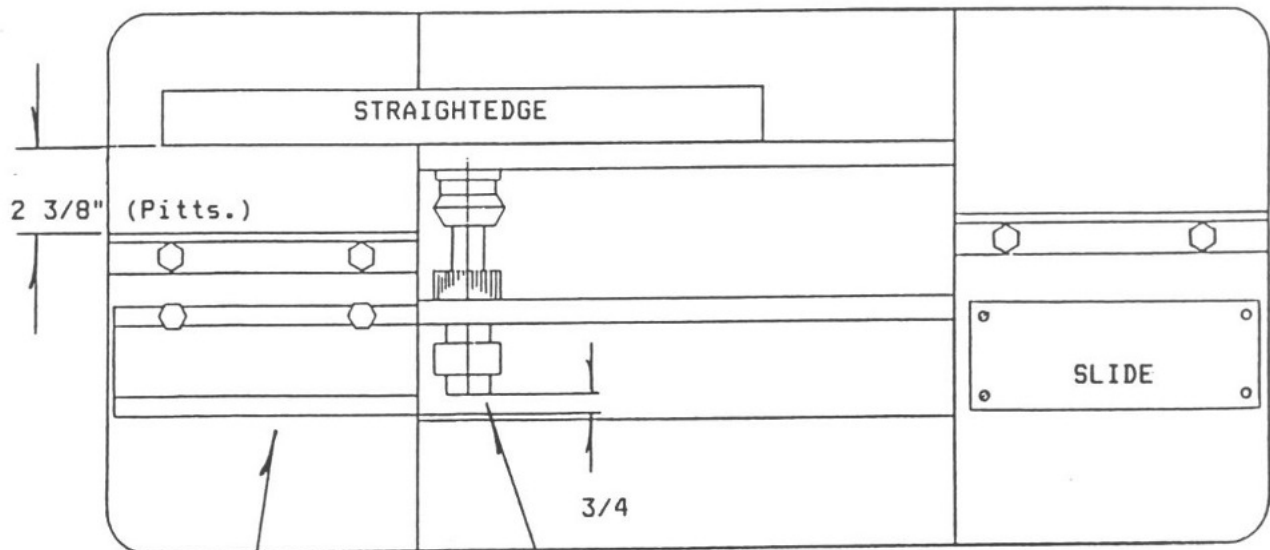

Drive
Cleat
Gage

For right angle flange and double seam
rolls lay straightedge against faces of
forming rolls and measure to face of
angle feed gauge. (See Chart)

Important: Disconnect Power Before Removing Covers for Any Reason



14-062



14-063



14-064



14-065



14-066



14-057



14-058



14-059



14-060



14-061



14-005



14-022



14-018



14-006



14-009



14-016



14-013



14-021

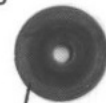

14-069



14-007



12-008



14-014

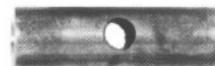

14-017

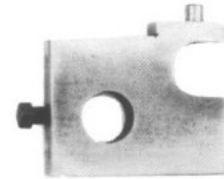

14-025



14-010



14-012



14-068



14-056



14-024



14-052



14-011



14-021



14-067



14-056

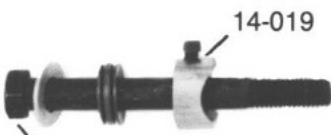

14-051

14-019



14-027



14-042

Parts List for Flagler Model 20 Standard

Part #	Description	Qty
14-001	Lower Front Plate	1
14-002	Lower Back Plate	1
14-003	Top Front Plate	1
14-004	Top Back Plate	1
14-005	#1 Pinion Gear*	1
14-006	#2 Pinion Gear*	1
14-007	#3 Pinion Gear*	1
12-008	Pinion Collar*	6
14-009	Bull Gear*	2
14-010	Roll Shaft (Top 3, 4, 5 & Bottom 5)*	4
14-011	Roll Shaft (Top 1, 2 & Bottom 1, 2, 3, 4)*	6
14-012	Roll Shaft Gear*	10
14-013	Idler Gear*	4
14-014	Plain Spacer*	5
14-016	Plain Step Spacer*	2
14-017	Drilled Plain Spacer*	2
14-018	Drilled & Tapped Step Spacer*	2
14-051	Hold Down Bolt – 5/8 – 11 NC	2
14-019	Saddle Washer*	2
14-055	Spring Washer 5/8" I.D.	8
14-054	Spring Washer 3/8" I.D.	12
14-021	Bearing 1412*	24
14-022	Bearing 1212-OH*	6
14-056	Bushing*	2
14-052	Snap Ring*	2
14-024	Idler Roll Pin*	2
14-025	Opening Roll Holder*	1
14-026	Head Spacer Shims (Pair)	2
14-027	Stud 3/8" – 16 NC*	2
14-028	Cover Assembly	1
14-031	Cabinet Assembly	1
14-041	Lube Line Assembly – 12"	3
17-046	Lube Line Assembly – 16"	3
14-042	Take Off Gauge*	1
14-042-H	Hardened Feed Gauge	1
14-044	Motor 3/4 HP	1
14-046	Pulley (motor)	1
12-040	Pulley (driven)	1
14-047	"V" Belt	1
10-036	Cord	1
14-057	Bottom 1 Pittsburgh Roll*	1
14-058	Bottom 2 Pittsburgh Roll*	1
14-059	Bottom 3 Pittsburgh Roll*	1
14-060	Bottom 4 Pittsburgh Roll*	1
14-061	Bottom 5 Pittsburgh Roll*	1
14-062	Top 1 Pittsburgh Roll*	1
14-063	Top 2 Pittsburgh Roll*	1
14-064	Top 3 Pittsburgh Roll*	1
14-065	Top 4 Pittsburgh Roll*	1
14-066	Top 5 Pittsburgh Roll*	1
14-067	Bottom Idler Roll*	1
14-068	Top Idler Roll*	1
14-069	Opening Roll*	1

*Denotes illustrated part.

Contact your Flagler Distributor for price and availability of these and other Flagler Products.

Important: Disconnect Power Before Removing Covers for Any Reason

flagler

56513 PRECISION DR.
CHESTERFIELD, MI 48051
P. 586.749.6300 F. 586.749.6363
WWW.FLAGLERCORP.COM

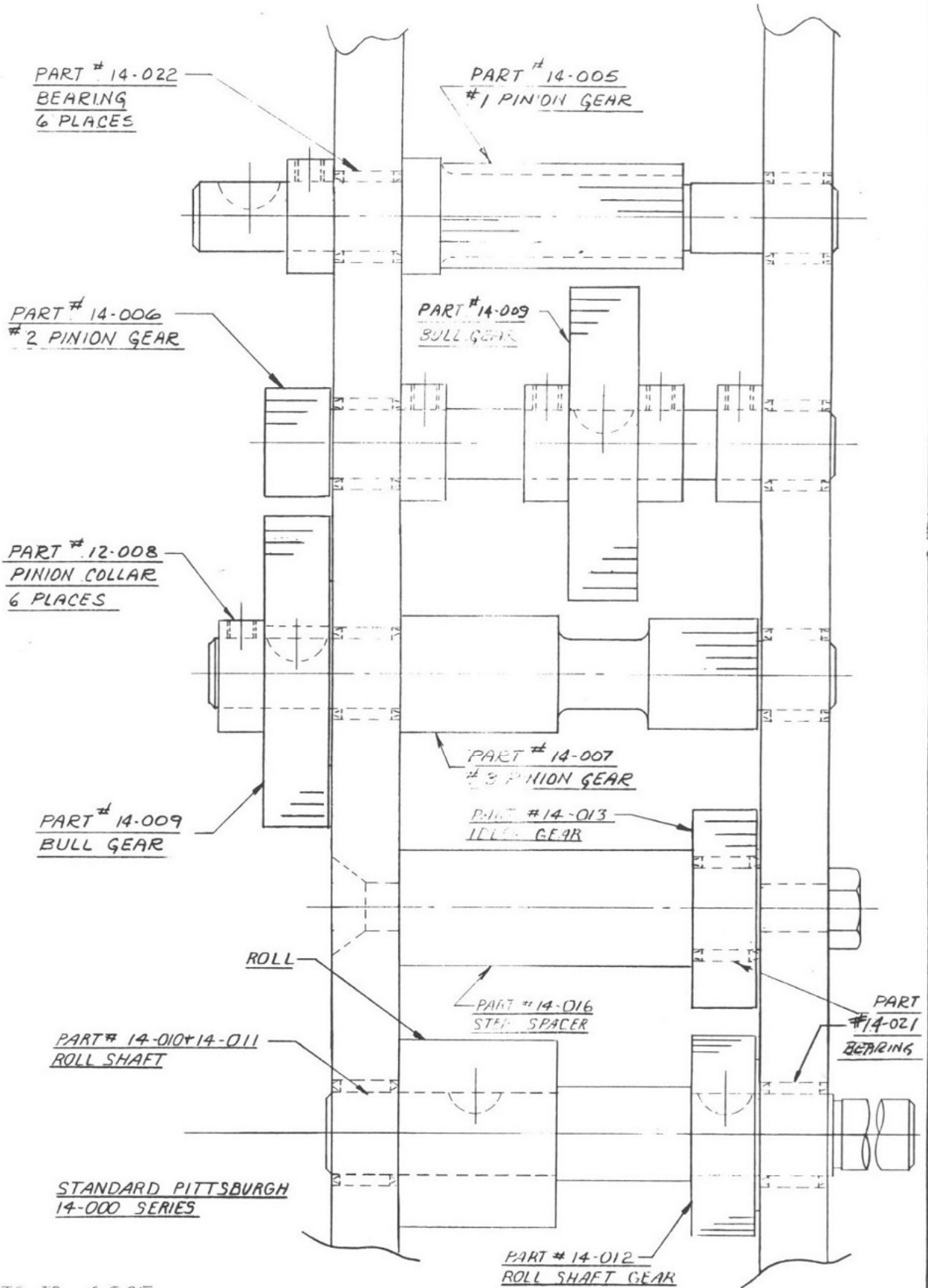

20 GA. STANDARD SPRING WASHER ASSY. INSTRUCTIONS
TO WORK PROPERLY THE ASSYS. MUST BE STACKED AS SHOWN.

3/8 HOLD DOWN STUDS

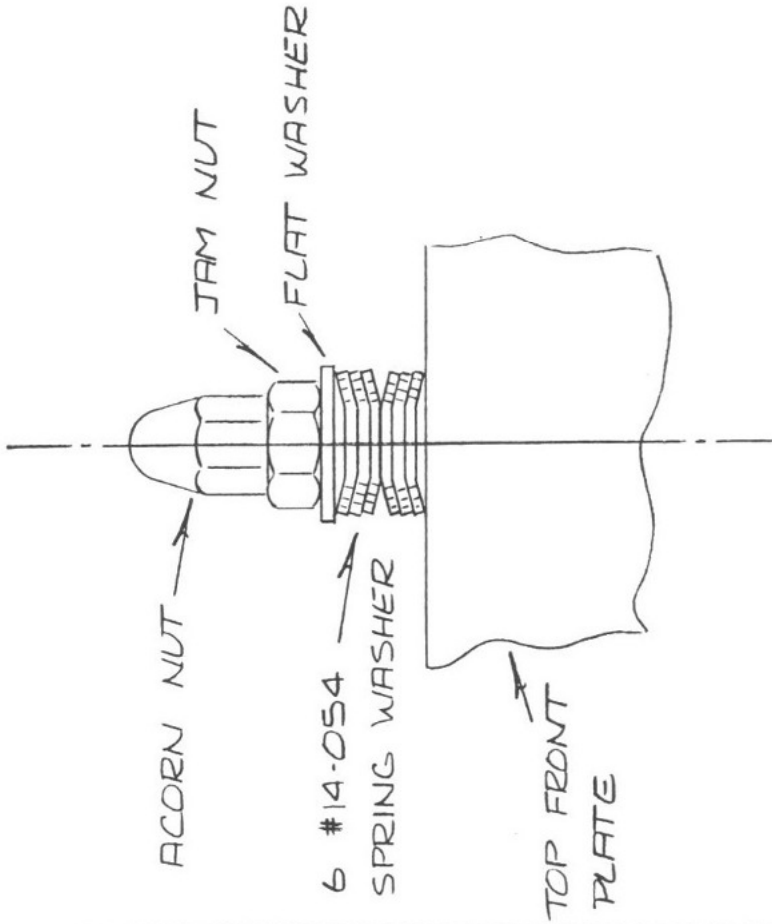

WHEN INSTALLING TIGHTEN JAM NUT
UNTIL SPRING WASHERS ARE FLAT
THEN BACK OFF 1/2 TURN AND TIGHTEN
ACORN NUT

5/8 HOLD DOWN

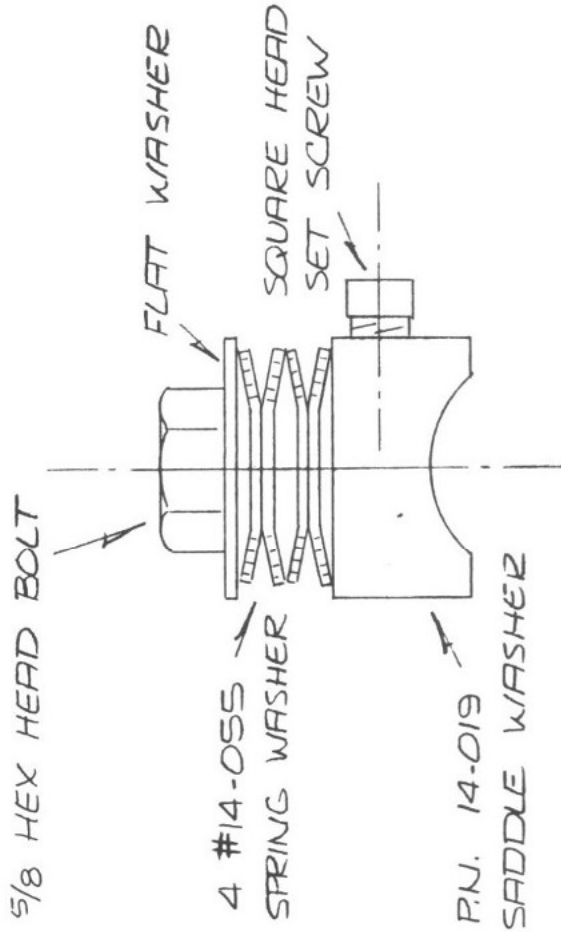

WHEN INSTALLING TIGHTEN 5/8 BOLT
UNTIL SPRING WASHERS ARE FLAT
THEN BACK OFF 3/4 TURN AND
TIGHTEN SQUARE HEAD SET SCREW.

Operating Instructions for Power Flanging Attachment

1. Tighten the gauge adjustment screw and loosen it a quarter turn (this setting is correct for 26 gauge material). If the flange is wrinkled, the adjustment is too tight; if there is slippage, then it is too loose
2. Turn up a "starting flange" by using the slot cut in the tabletop. Once the operator is accustomed to the flanger, this will not be necessary. As the metal passes through the forming rolls, exert a small force on the piece in the direction indicated by the arrows in the figure below. This holds the metal to the height gauge and results in an even, uniform flange. Too much force will jam the machine.
3. On exceptionally small outer radii the piece may need to be run through the flanger a second time to remove wrinkles and to straighten the flange.
4. When flanging straight pieces or pieces having a constant radius, the operator may set the adjustable guide. To use the guide simply run a piece partly through the rolls and then slid the guide against the flange and tighten down the T-handle. As a result, the following pieces can be released after started.
5. To flange small inner radii, no guide is needed. Start the piece and LET GO.
6. If you fail to turn the flange to the full height, or the flange runs off the edge of the piece, the piece is not spoiled; simply run it through the flanger again.
7. After flanging a few pieces, the operator will get the "feel" of the machine and find out how easily that the metal is guided up to a perfect flange. For ease in handling of material, stand at the front of the machine.

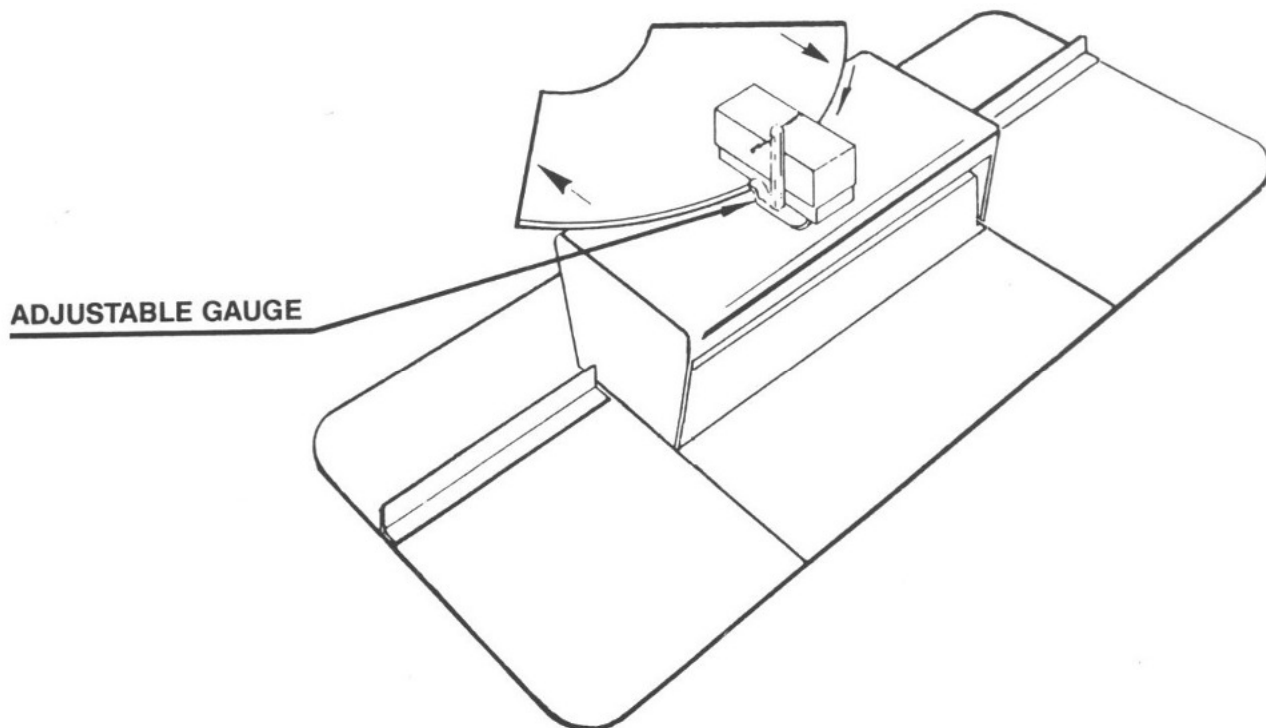

Important: Disconnect Power Before Removing Covers for Any Reason

56513 PRECISION DR.

CHESTERFIELD, MI 48051

Phone 586.749.6300

Fax 586.749.6363

WWW.FLAGLERCORP.COM