

# **BAW**

## **PLATINUM EDITION**

**BAW570 ITEM #27185**  
**BAW270 ITEM #27183**  
**SPOTWELDER**



**New machine  
COMING SOON!**

**OWNER'S  
MANUAL**

**DURO  
DYNE**

**MACHINERY  
DIVISION**



## INTRODUCTION

Duro Dyne's new simple to use spotwelder with its deep throat can be used as a duct welder or to do standard types of spot welding. It comes with a Welding Transformer that is efficient but still powerful. It has unique water cooled arms and a simple water circulating cooling system that will ensure the arms will not overheat and stay cool to the touch.

This Guide is designed to help you set up and operate your BAW at peak performance for years to come.

## IMPORTANT

Always follow manufacturer's recommendations for proper safety and handling procedures for all materials used in conjunction with this machine as outlined in Manufacturer's Safety Data Sheet (SDS) for each product.

## LIMITED WARRANTY

Duro Dyne Machinery is manufactured by skilled mechanics, utilizing the latest production techniques. Each unit has been rigorously tested prior to packaging and shipment in order to ensure trouble-free operation.

Your Duro Dyne machine has a two year warranty against defects in material. Any component found to be defective will be repaired or replaced (at the manufacturer's discretion) at no cost if the faulty component is returned freight prepaid to the nearest Duro Dyne Service Department. The warranty does not apply to expendable parts or repairs or service due to improper maintenance or operation procedures.

Duro Dyne products have been engineered to maximize operator safety. Unauthorized modification of this product will void the warranty.

All warranty claims must be accompanied by a serial number, date of purchase and the name and address of the distributor it was purchased from.

## TABLE OF CONTENTS

Installation Instructions	13-14
Introduction	2
Maintenance	14
Notes	19
Parts List	18
Parts Locator	3-11
Servicing	15
Troubleshooting	15-17
Warranty	2
Wiring Diagram	12

# PARTS LOCATION

---

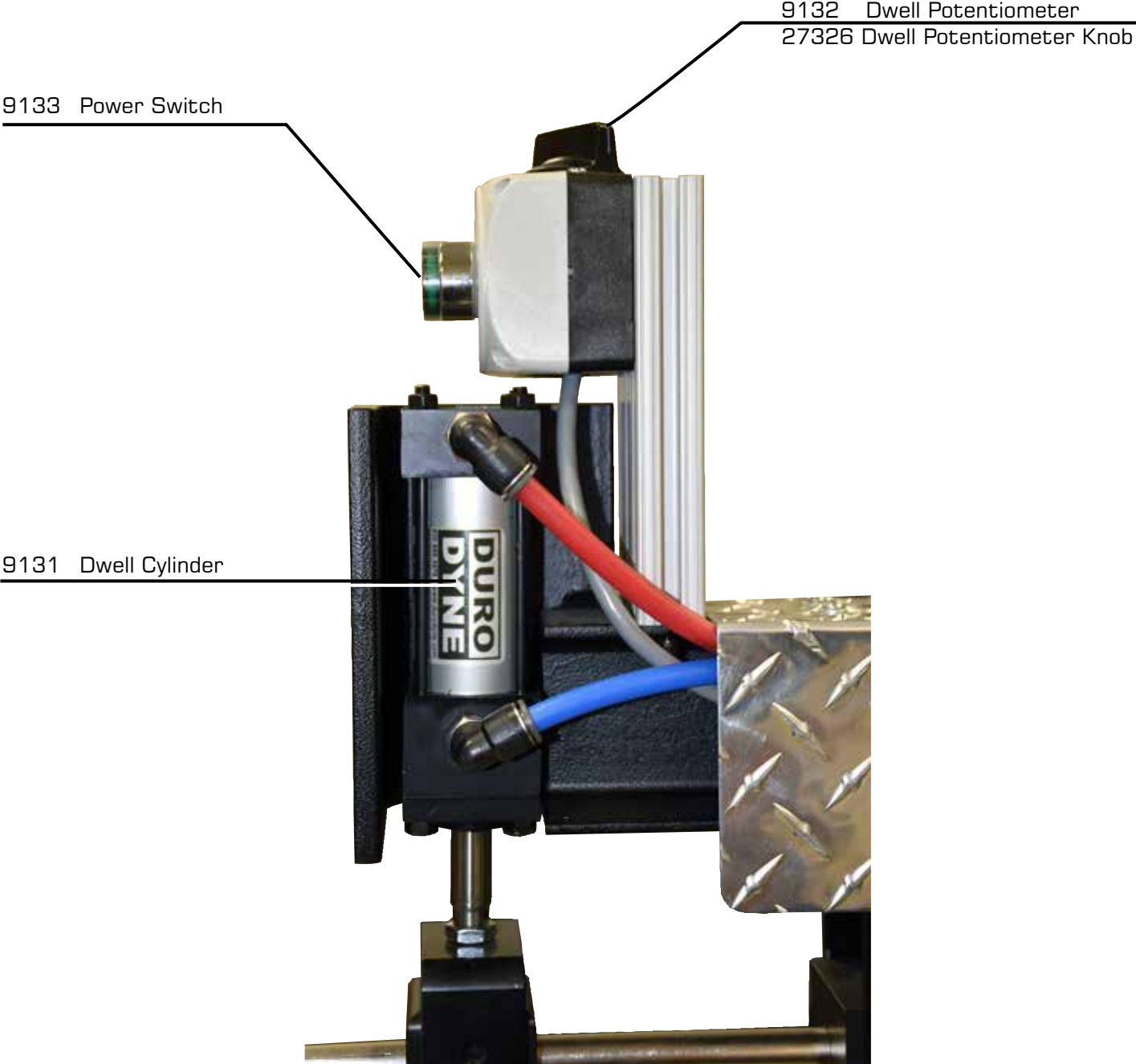

---

## FRONT CONTROL BOX

# PARTS LOCATION

---

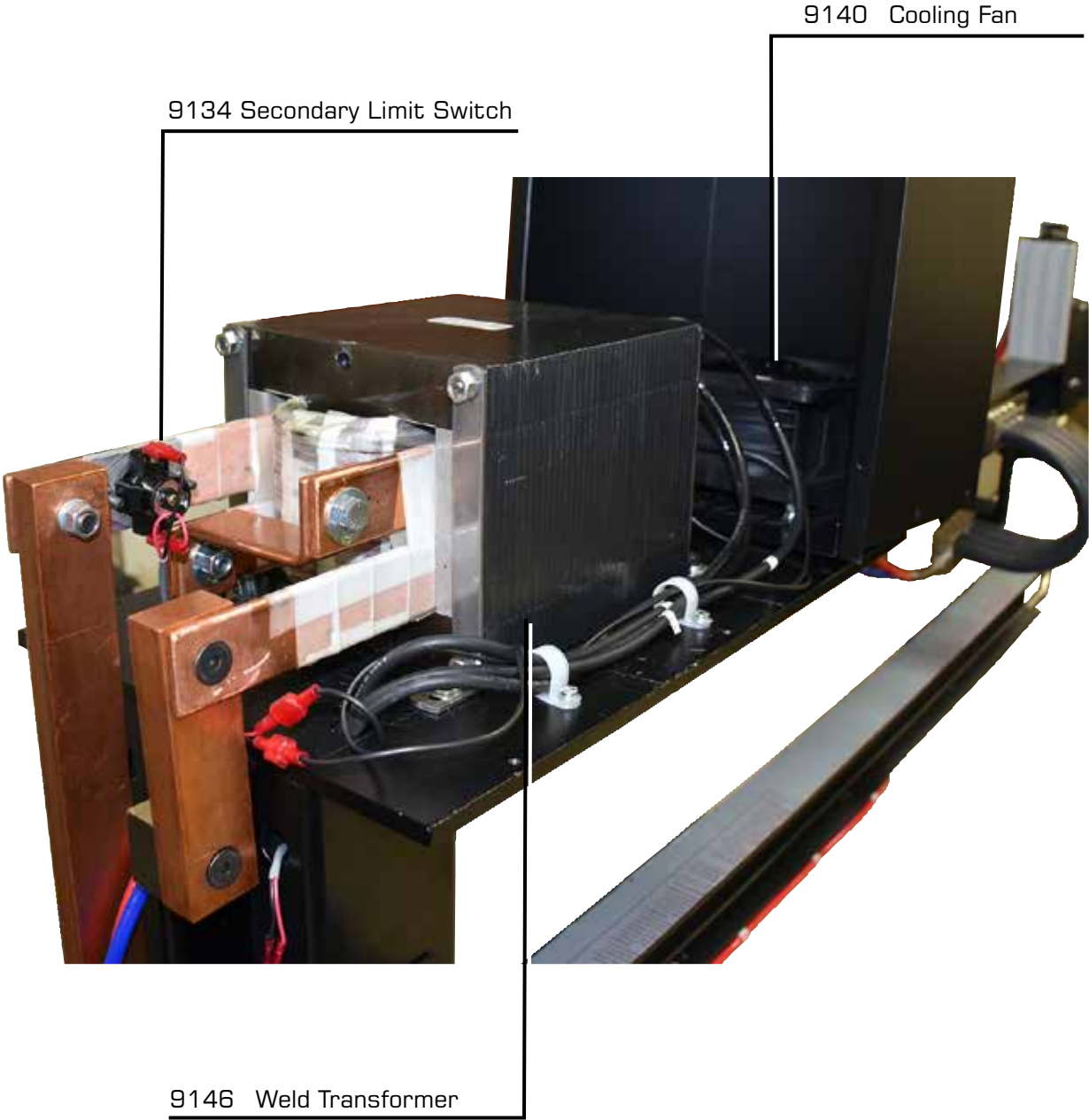

---

## WELD TRANSFORMER

# PARTS LOCATION

---

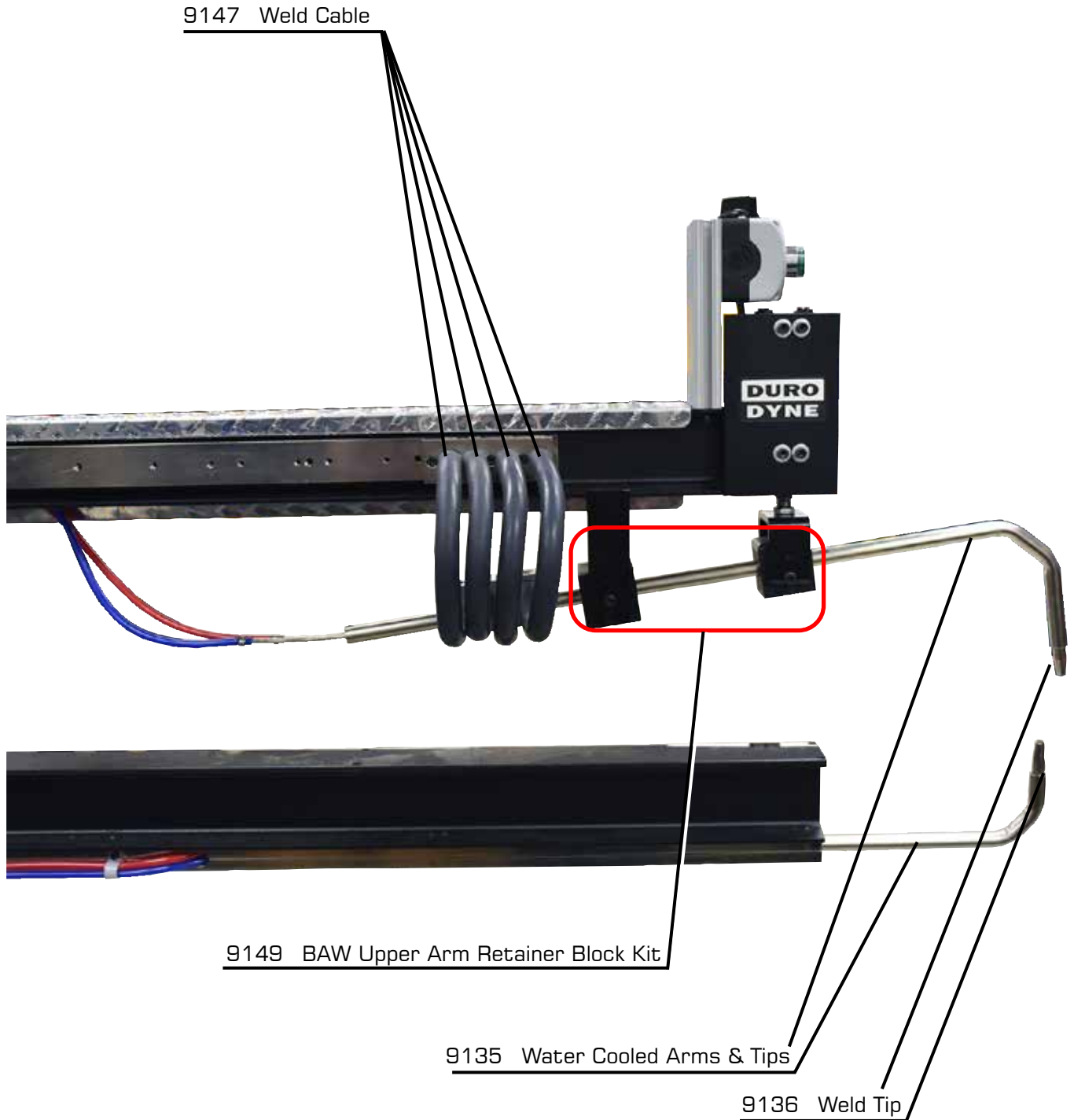

---

## WELD ARMS, TIPS & CABLES

# PARTS LOCATION

---

17377 Air Regulator

9137 Dwell Solenoid



17356 Adjustable Muffler

17325 Weld Pressure Switch

---

## AIR REGULATOR & SOLENOID

# PARTS LOCATION

---

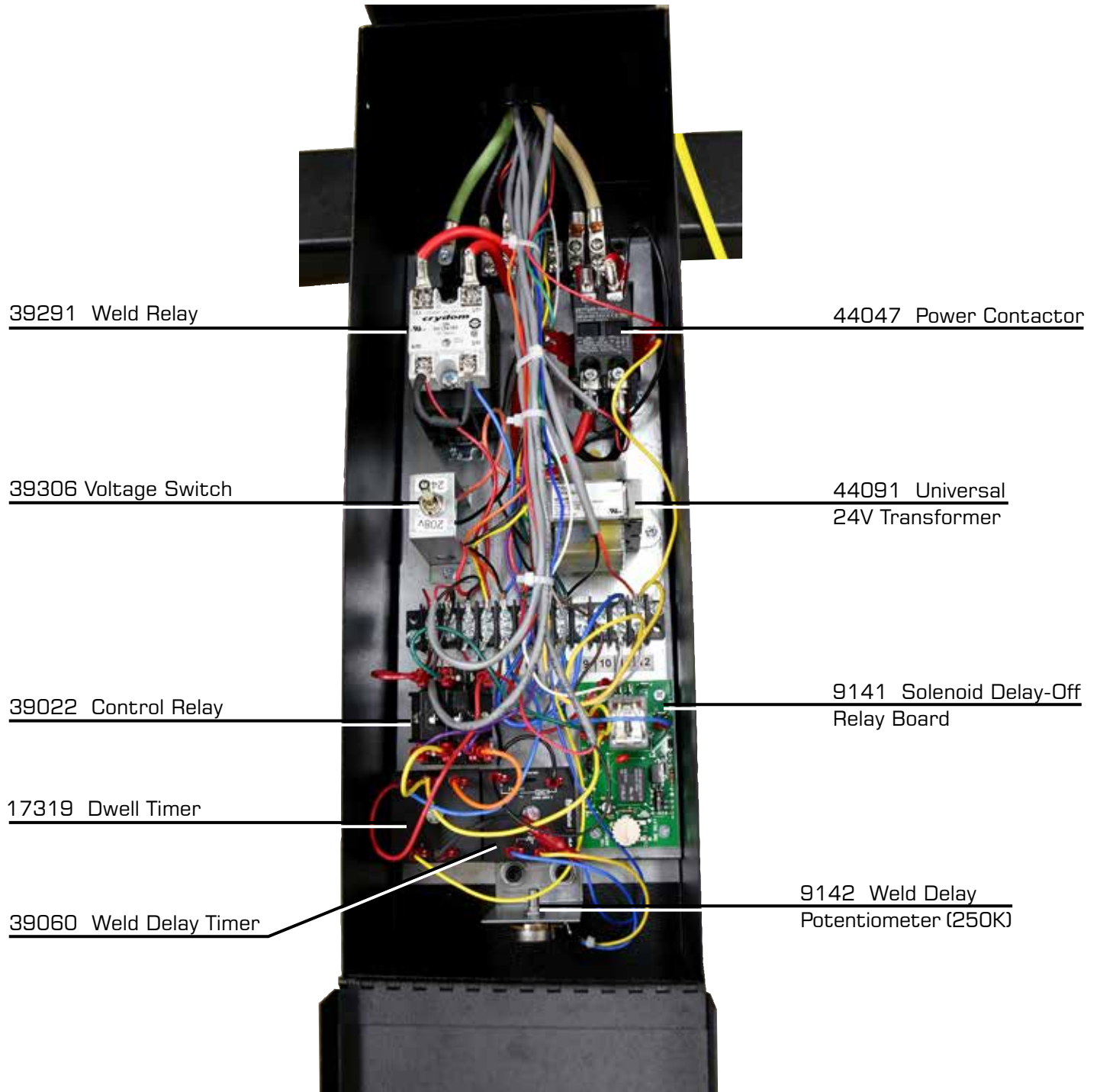

---

## COMPONENT MODULE

# PARTS LOCATION

---

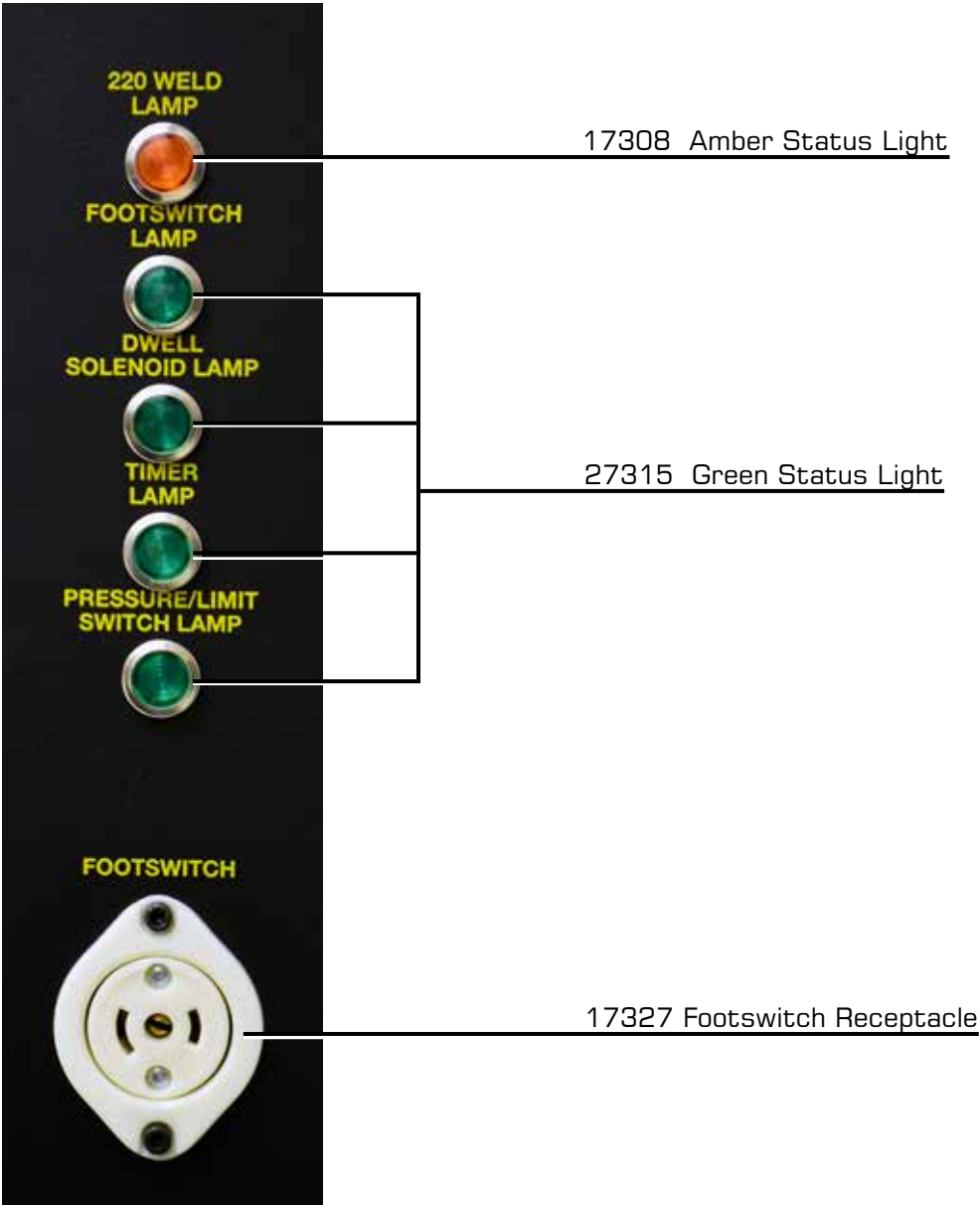

---

## LIGHTING PANEL



# PARTS LOCATION

---

9148 Cooling Pressure Switch



9143 Flanged Receptacle

44097 Pump Relay (not shown)

9144 Flanged Inlet

9145 Line Cord with Strain Relief

---

**REAR PANEL**

# PARTS LOCATION

---

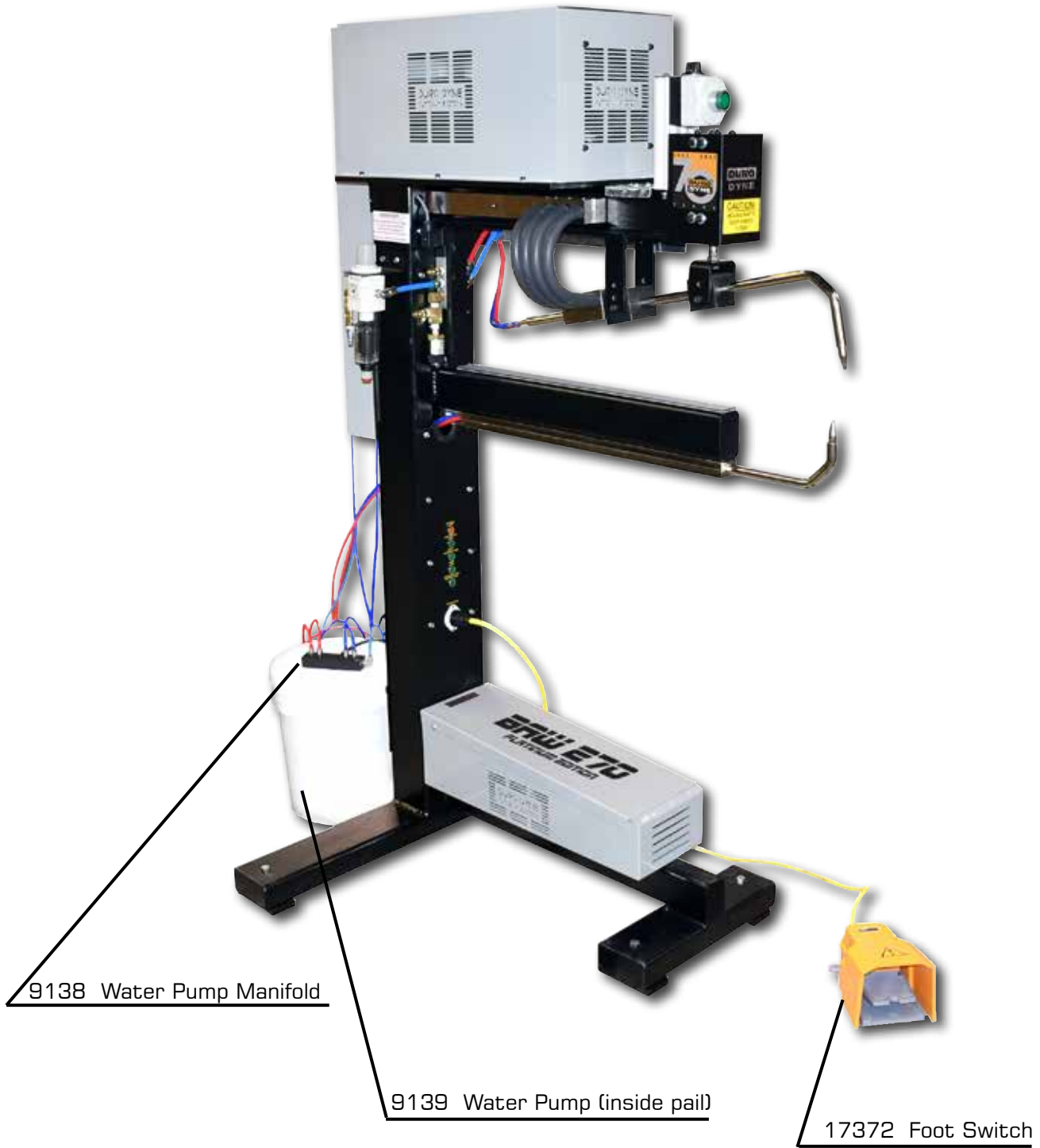

17135 Lift Kit (not shown)

**\*BAW270 Shown**

**WATER PUMP & COMPONENTS**

---

# PARTS LOCATION

---

Secure the Red and Blue Tubing to the Water Pump Manifold as shown below.

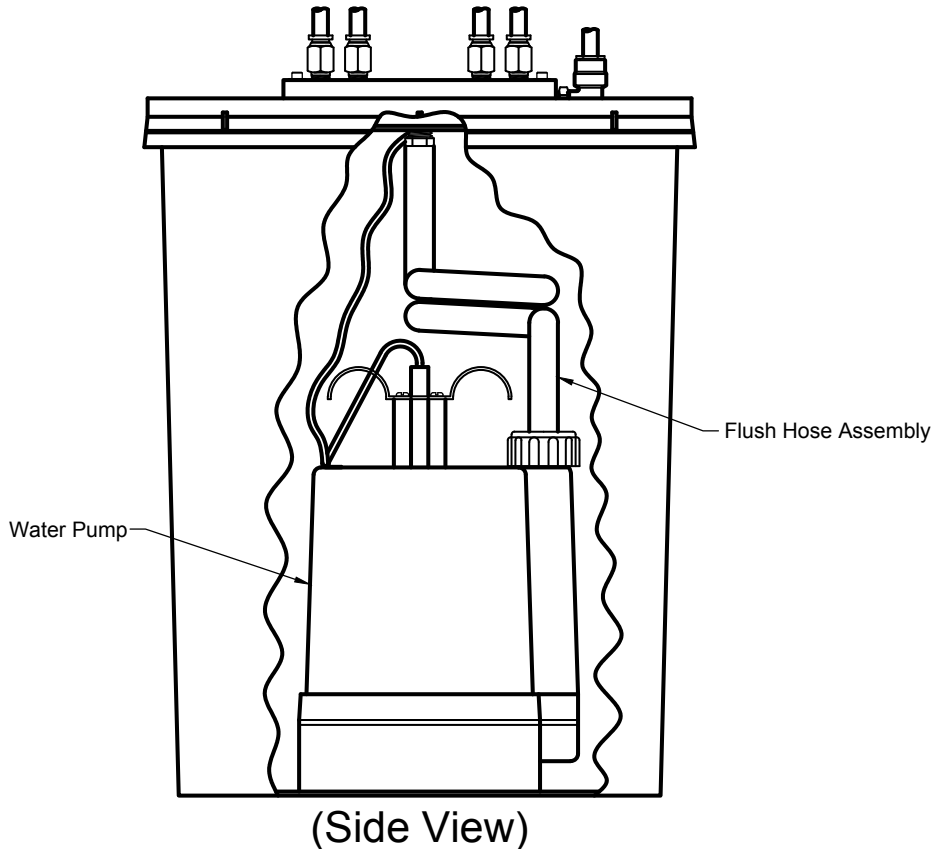
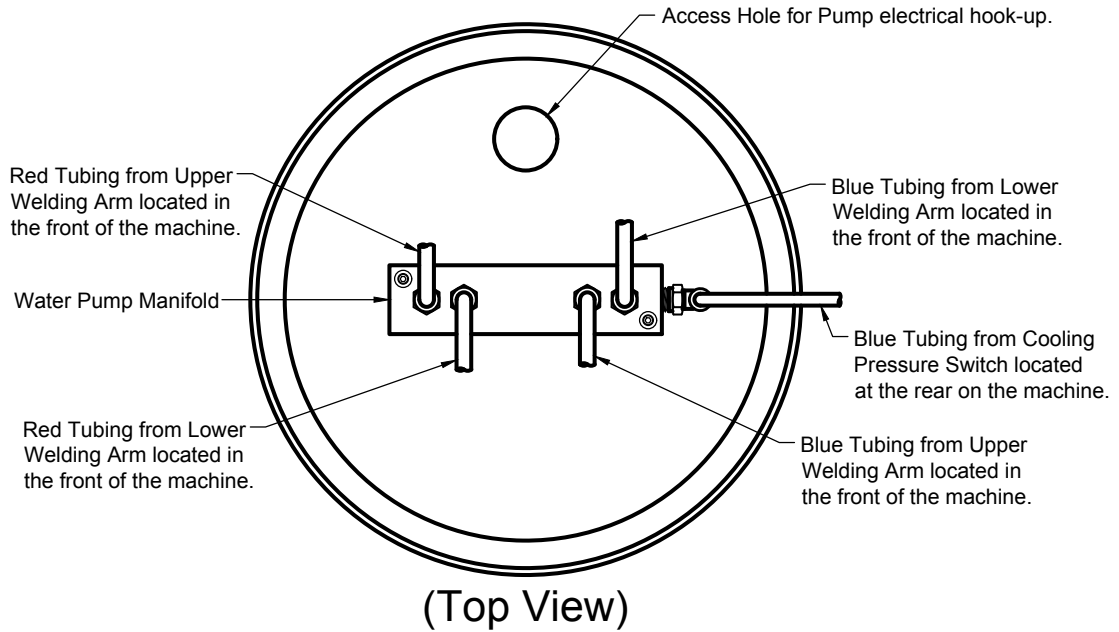

---

## WATER PUMP HOOK-UP

# WIRING DIAGRAM

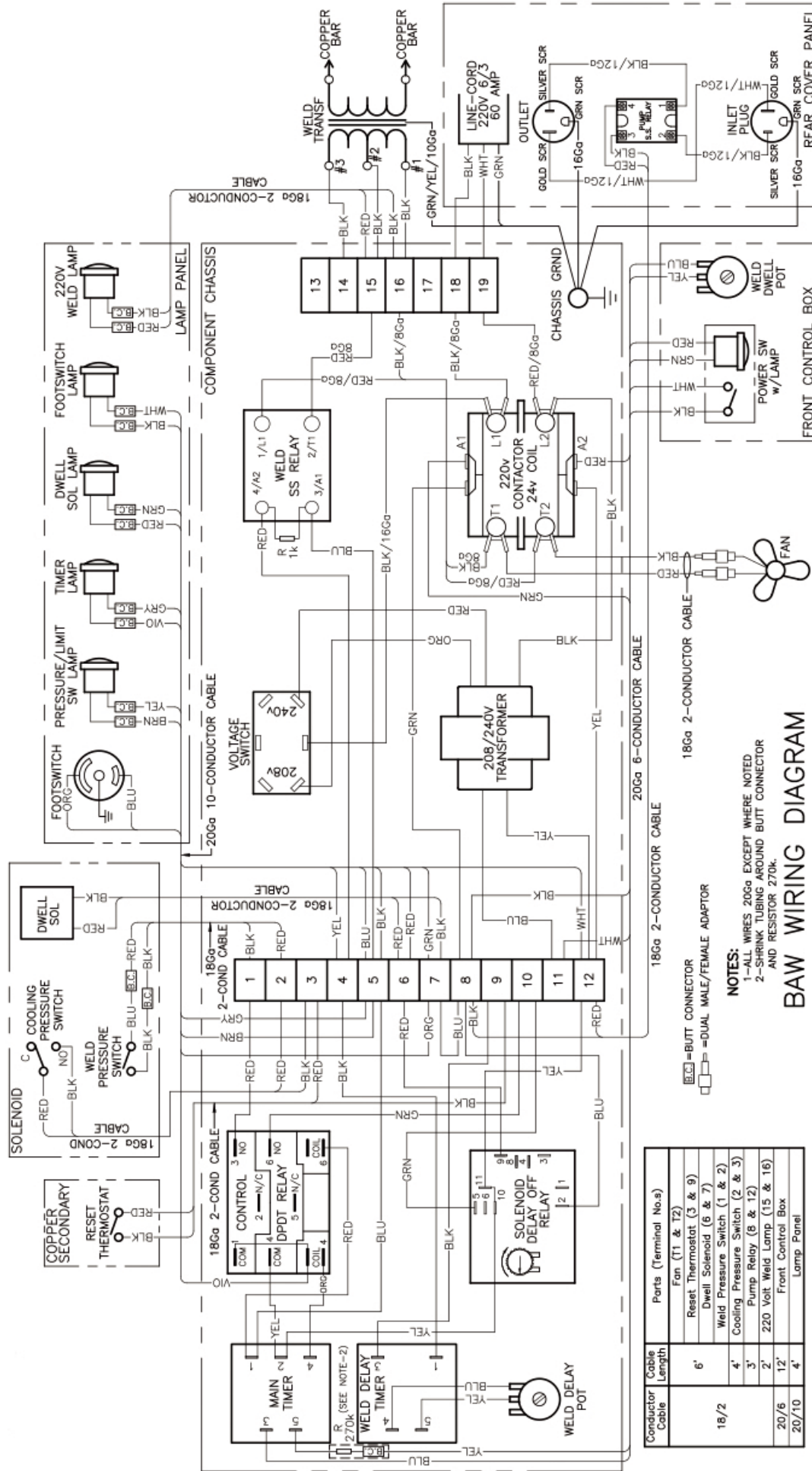

# BAW

# INSTALLATION INSTRUCTIONS

---

## Power Requirements:

208 to 240 VAC 60 HZ 100 Amp Single Phase Service. Minimum Circuit Protection 100 Amp (circuit protection must be of a type that will not be effected by inrush current [Slow Blow]). Duro Dyne recommends using the next size gauge wire over code when possible due to the inrush current. A 110 Volt extension cord must plugged into the Male Receptacle in the back of the BAW (For the Cooling Pump).

## Air requirements:

80 PSI @ 2 CFM. BAW Air Regulator to be set at 40 PSI.

---

## Set up:

Wire power cord to Single phase 208-240 Vac 100 amp service. Open component box (Bottom Rear) to select what voltage the 208/240 Control Voltage Transformer Switch must be in (select the one that most closely matches your incoming voltage). Open lid on Cooling Pail and remove pump. Fill Cooling Pail  $\frac{3}{4}$  of the way with clean cool water. Replace lid. Install Cooling Hoses to manifold on top of lid (See Page 11). Plug Pump Cord into female receptacle in rear of the BAW. Plug powered extension cord to male receptacle in rear of the BAW. Make sure Arms and Tips are aligned perfectly. Connect air and adjust regulator to 40 PSI.



# INSTALLATION INSTRUCTIONS

---

## Theory of Operation:

Press the Power Switch. This will supply low voltage to the Power Contactor coil now turning the high voltage on. The Cooling fan and Water Cooling Pump will now come on. Now when the Foot Switch is engaged it supplies power to the Dwell Timer. The Adjustment Knob above the Power Switch controls how long this timer stays on. The Dwell Timer controls the Control Relay that sends low voltage power through the Weld circuit and to the Solenoid circuit. The Weld circuit consist of: **1) The Weld Pressure Switch** (this will not allow the weld to come on until the tips are clamped to the metal [Hold]), **2) The Cooling Pressure Switch** (this switch will only allow the weld to engage if the Water Cooling Pump is on), **3) The Secondary Limit Switch** (this is a safety that will turn the weld off if the secondary near the transformer has overheated; after the secondary has cooled down, this Limit Switch will automatically reset and allow the weld to operate again), **4) The Weld Delay Timer** (this timer will delay the weld a fraction of a second to ensure the tip hold is good) and **5) The Solid State Weld Relay** that powers the Weld Transformer. At the same time that the weld circuit was engaged the Solenoid Delay-Off Relay was engaged energizing the Dwell Solenoid pressurizing the cylinder to close the welding arms. When the Dwell Timer times out the weld circuit will end but the Solenoid Delay-Off Relay will remain engaged for a few moments longer allowing the weld to cool before releasing the hold.

## Initial Use:

Make sure air is on and regulator is set to 40 PSI. Turn power on. Take steel that is to be spot welded and place in position on bottom tip. Press foot pedal and weld. Inspect weld. If weld does not seem to be strong enough increase time by turning knob clockwise on top of the Control Box. If too hot decrease time by turning counter clockwise. After several welds check tips to see that they are remaining cool (CAUTION! Tips will be hot enough to burn if cooling system is not working properly). When cooling system is working correctly tips will be safe to touch almost immediately after welding.

**~CAUTION! Never cycle the machine without metal between the tips~**

# MAINTENANCE

---

Keep Tips and Arms clean by using an aluminum oxide hand pad (example Scotch Brite) to remove galvanize flashing and other build up. Keep water in cooling pail clean. Change regularly. When replacing tips a little amount of High Temperature RTV silicone maybe applied to taper of tip to keep cooling water from leaking out.

# SERVICING

## A SIMPLIFIED STEP-BY-STEP PROCEDURE

Duro Dyne has called upon its many years of spotwelding experience in designing the BAW. Your unit has been rigorously factory tested and inspected to provide many years of dependable service.

## WHAT TO DO BEFORE YOU BEGIN TROUBLESHOOTING:

### CONSULT THE MANUAL.

Most of the functional problems that occur are due to an oversight in the set-up, operational or normal maintenance procedures. Therefore, you should re-check all "Set Up", "Initial Adjustment", "Operation" and "Maintenance" procedures.

### INSPECT THE UNIT

If the problem still persists, the next step is careful visual inspection. Turn off the electricity - that is, disconnect your Spotwelder from its power supply and carefully check the component module for loose, broken or disconnected wires. Also check the air circuit for leaky air connections or cut hoses.

### HOW TO IDENTIFY WELD QUALITY PROBLEMS

There are five indicators lamps to help identify a problem if one should occur. A test meter will be needed to confirm diagnosis. Always have metal between the tips when cycling the machine. If you feel that you will need assistance with trouble shooting your BAW Duct Welder please call Technical Services at 1 800 899 3876.

**Note:** Weld quality can also be affected by air pressure. If the weld is too hot, increase the air regulator pressure to 80 PSI. May need to readjust the adjustable mufflers for arm speed.

# TROUBLESHOOTING

Your BAW Spotwelder is equipped with indicator lamps that will assist you in quickly locating the probable cause should your machine fail to operate. While the lamps can point you to a defective component, it is recommended that a volt meter be used to verify the indication. In some cases a loose or broken wire could cause a false indication.

This troubleshooting section has been divided into separate sections on the type of component:

**220V WELD LAMP**

**FOOTSWITCH LAMP**

**DWELL SOLENOID LAMP**

**TIMER LAMP**

**PRESSURE/LIMIT LAMP**

**POWER SWITCH WITH INDICATOR LAMP**

After determining the type of problem, go to that section, cycle the machine watching the indicator lights and then follow the instructions in that section. If further assistance is needed, you may call the Duro Dyne Technical Services Department at 1-800-899-3876 between the hours of 8am - 7pm EST.

# TROUBLESHOOTING (continued)

---

There are six indicator lamps to help identify a problem if one should occur. A test meter will be needed to confirm diagnosis. Always have metal between the tips when cycling the machine. If you feel that you will need assistance with trouble shooting your BAW Duct Welder please call Technical Services at 1 800 899 3876.

- 1) 220 Volt Weld Lamp:** This lamp indicates that the primary side of the Weld Transformer is being powered. When the tips come together and stop moving (Hold) this lamp will come on momentarily and then go off. If this lamp is the only one that fails to come on and the machine fails to weld this most likely means that the Weld SS Relay or the Contactor has failed. To check the Contactor test for voltage (24 VAC) at terminals 8 and 12 on the terminal strip. If voltage is not present go to Step-6. If the voltage is present now test for voltage (Caution! 220VAC) at terminals T1 and T2 on the Contactor. If voltage is not present replace the Contactor. If the voltage is present now test for voltage (220 VAC) terminals 15 and 16 on the terminal strip while cycling the machine. If voltage is not present when the machine is cycled and the 220 Weld Lamp is the only lamp that does not come on replace the Weld SS Relay. If this lamp remains on all the time alone (by itself) this means the Weld SS Relay has failed in a closed circuit. The machine may still weld when in this condition but will over heat the Weld Transformer and may damage the machine. Discontinue use until the Weld SS Relay is replaced. To test this relay during this condition check for voltage (24 VAC) at terminals 3/A1 and 4/A2 on the Weld SS Relay. If voltage is present when the machine is NOT cycled test the Dwell Timer circuit (see Step-4). If the voltage is not present now test for voltage at terminals 15 and 16 on the terminal strip. If voltage is present when the machine is NOT cycled replace Weld SS Relay.
- 2) Footswitch Lamp:** This lamp indicates when the Footswitch is depressed and will remain on as long as the footswitch is depressed. If the Power Indicator Lamp (in the Power Switch) is on and the Footswitch Lamp does not light when Footswitch is depressed repair or replace Footswitch. The Footswitch can be tested with a meter, Set meter to ohms and put leads on outside prongs of the plug. Infinite ohms when the Footswitch is not depressed and zero ohms when it is depressed.
- 3) Dwell Solenoid Lamp:** This lamp indicates that the Dwell Solenoid has power going to it. If the Welding Arms do not move when this lamp is on, check the Regulator pressure for correct setting (40 PSI) and that the Welding Arms move freely when the air is turned off. If so replace the Dwell Solenoid. If all the lamps are working but the Dwell Solenoid Lamp check for voltage (24VAC) at terminals 8 and 10 on the terminal strip when cycling the machine. If voltage is present replace Solenoid Delay-Off Relay. If the voltage is not present when the machine is cycled replace the Control Relay.
- 4) Timer Lamp:** This lamp indicates that the Dwell Timer output is on. If this lamp does not come on along with all the others (except the Footswitch Lamp) when cycled, replace the Dwell Timer. To test the Dwell Timer with a meter check voltage (24 VAC) at terminals 1 and 2 (input) on the Dwell Timer while cycling the machine (push-on connectors may have to be lifted to access terminals). If voltage is not present return to Step-2. If the voltage is present now check voltage at terminals 1 and 4 (output) on the Dwell Timer when cycling the machine. If voltage is not present replace Dwell Timer. If voltage is present go to Step-5.
- 5) Pressure/Limit Lamp:** This lamp indicates that the Pressure and Limit Switches are all functioning. If this lamp does not come on when the machine is cycled, before doing any of the testing below, make sure that there is sufficient water in the pail and the Cooling Pump is running and circulating the water properly.
  - A)** The Weld Pressure Switch is first in this circuit. It turns the weld on when the tips come together and they have a good hold on the metal. If the Pressure/Limit Lamp along with Weld Lamp do not come on when the machine is cycled test for voltage (24VAC) at terminals 1 and 8 on the terminal strip when cycling the machine. If the voltage is not present and the Timer Lamp comes on when the machine is cycled replace the Control Relay. If the voltage is present, now test for voltage (24VAC) at terminals 2 and 8 on the terminal strip when cycling the machine. If the voltage is not present replace the Weld Pressure Switch. If the voltage is present go to Step-B.



# TROUBLESHOOTING (continued)

---

**B)** The Cooling Pressure Switch will keep the weld off if it does not sense pressure from the Cooling Pump. If the Pressure/Limit Switch Lamp along with the Weld Lamp do not come on, test for voltage (24VAC) at terminals 2 and 8 on the terminal strip when cycling the machine. If voltage is not present when the machine is cycled return back to Step-A. If voltage is present, now test for voltage at terminals 3 and 8 on the terminal strip when cycling the machine. If voltage is not present replace Cooling Pressure Switch. If voltage is present go to the next step.

**C)** Secondary Limit Switch will shut the weld down if the Copper Secondary near the Weld Transformer overheats. When it cools down, the machine will function properly again. If the Pressure/Limit Lamp along with the Weld Lamp does not come on when the machine is cycled test for voltage (24VAC) at Terminals 3 and 8 on the terminal strip when cycling the machine. If the voltage is not present return to back to Step-B. If the voltage is present now test for voltage at terminals 8 to 9 on the terminal strip when cycling the machine. If the voltage is not present replace the Secondary Limit Switch. If voltage is present go to the next step.

**D)** Weld Delay Timer works along with the Weld Pressure Switch to insure that the Tips have a good hold on the metal before the weld turns on. If the Pressure/Limit Switch Lamp along with the Weld Lamp do not come on when the machine is cycled test for voltage at terminals 8 and 9 on the terminal strip. If voltage is not present when the machine is cycled return back to Step-C. If the voltage is present now test for voltage at terminals 4 and 9 on the terminal strip when cycling the machine. If the voltage is not present replace the Weld Delay Timer.

**6. Power Switch with Indicator lamp:** This switch will energize the coil on the Contactor that supplies the high voltage to the Welding Circuit and the Cooling Fan. It also supplies 24 VAC to the control circuit. If the Power Indicator Lamp (in the Power Switch) does not come on when switch is depressed and the machine does not operate at all, test for voltage (Caution 220 VAC) at terminals 18 and 19 on the terminal strip. If voltage (220 VAC) is not present check incoming power supply. If Voltage is present test for voltage (24 VAC) at terminals 11 and 12 on the terminal strip. If voltage is not present replace 208/240 Step-Down Transformer. If voltage is present test for voltage (24 VAC) at 8 and 12 on the terminal strip. If the voltage is not present replace Power Switch.

**~CAUTION! Never cycle the machine without metal between the tips~**

# PARTS LIST

---

9131	BAW DWELL CYLINDER
9132	BAW DWELL POTENTIOMETER
9133	BAW POWER SWITCH
9134	BAW SECONDARY LIMIT SWITCH
9135	BAW WATER COOLED ARMS & TIPS
9136	BAW WELD TIP
9137	BAW DWELL SOLENOID
9138	BAW WATER PUMP MANIFOLD
9139	BAW WATER PUMP
9140	BAW COOLING FAN
9141	BAW SOLENOID/DELAY-OFF RELAY BOARD
9142	BAW WELD/DELAY POTENTIOMETER
9143	BAW FLANGED RECEPTACLE
9144	BAW FLANGED INLET
9145	BAW LINE CORD w/STRAIN RELIEF
9146	BAW WELD TRANSFORMER
9147	BAW WELD CABLE
9148	BAW COOLING PRESSURE SWITCH
9149	BAW UPPER ARM RETAINER BLOCK KIT
17135	LIFT KIT
17308	AMBER STATUS LIGHT
17319	DWELL TIMER
17325	WELD PRESSURE SWITCH
17327	FOOTSWITCH RECEPTACLE
17356	QUICK EXHAUST ADJUSTABLE MUFFLER
17372	FOOT SWITCH
17377	AIR REGULATOR
27315	GREEN STATUS LIGHT
27326	DWELL POTENTIOMETER KNOB
39022	CONTROL RELAY
39060	WELD DELAY TIMER
39291	WELD RELAY
39306	VOLTAGE SWITCH
44047	POWER CONTACTOR
44091	UNIVERSAL 24V TRANSFORMER
44097	PUMP RELAY

# NOTES

A series of horizontal grey bars for writing notes, starting below a hatched line and ending above the footer.



Please Visit Our Website  
**[www.durodyne.com](http://www.durodyne.com)**

for the most up to date product information.



**MACHINERY DIVISION**

© 2022 Duro Dyne Corporation

Printed in USA 2/2/2022

BI027410

**Duro Dyne Corporate Headquarters, Bay Shore, NY**

**631-249-9000 • Fax: 631-249-8346**

**Duro Dyne Midwest • Duro Dyne West • Duro Dyne Canada**

**[www.durodyne.com](http://www.durodyne.com) • E-mail: [durodyne@durodyne.com](mailto:durodyne@durodyne.com)**