

SPIRAL WAND

GENERAL DESCRIPTION

The Duro Dyne Spiral Wand foot pedal activated gun works with your PBF and MF units. The 4½ ft compact design allows pinning in small diameter round pipe and is able to reach the center of 10 ft spiral duct. The magnetic tip hold pins for precision placement.

Wand, cable, and foot pedal included.

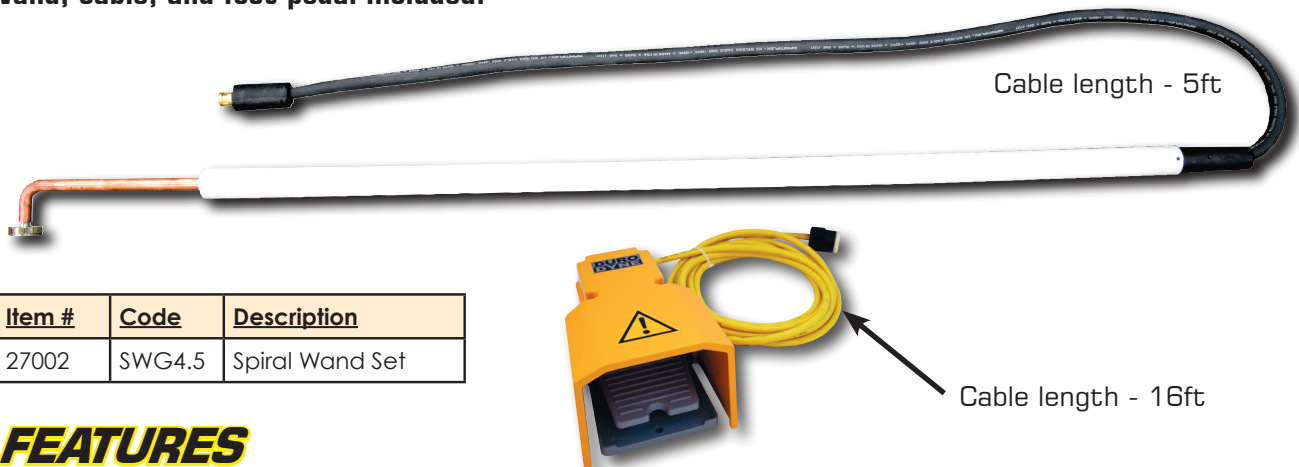

Item #	Code	Description
27002	SWG4.5	Spiral Wand Set

FEATURES

- Works with PBF and MF style Pinspotters
- Overall length 4½ ft.
- Able to reach center of 10 ft. spiral
- Compact design allows pinning in small diameter round pipe
- Magnetic tip hold pins for precision placement

WORKS GREAT WITH THESE PRODUCTS:

PBF Pinspotter



MF Pinspotter



Duro Dyne East Division, Bay Shore, NY 631-249-9000 Fax: 631-249-8346
Duro Dyne Midwest Division, Hamilton, OH 513-870-6000 Fax: 513-870-6005
Duro Dyne West Division, Longmont, CO 562-926-1774 Fax: 562-926-5778
Duro Dyne Canada, Lachine, Quebec, Canada 514-422-9760 Fax: 514-636-0328
www.durodyne.com E-mail: durodyne@durodyne.com

MACHINERY DIVISION
5/1/2023



27002 SWG4.5 Spiral Weld Gun Installation Instructions

IMPORTANT: First turn off all air and electrical power to machine before proceeding.

PBF-Series Units (Includes the PBFS14 unit)

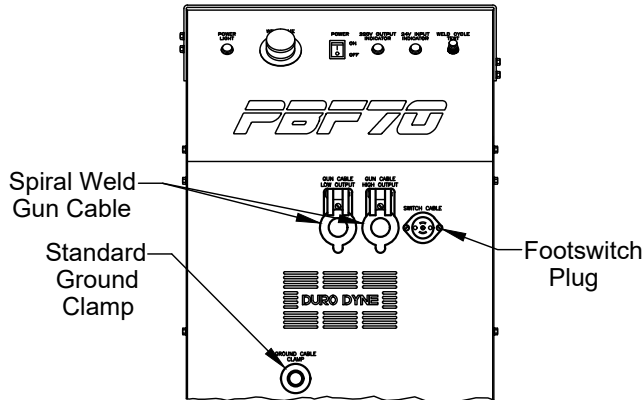

RH70 Units (Junction Box Located on Front Leg)

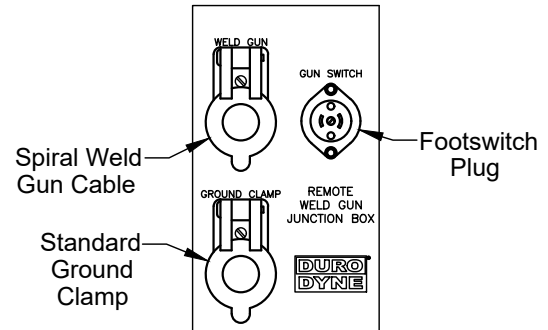

RH70 Notes: The 10ft Ground Clamp is required for this application (as listed below).

MF-Series Units

Will NOT work with the MFPT unit

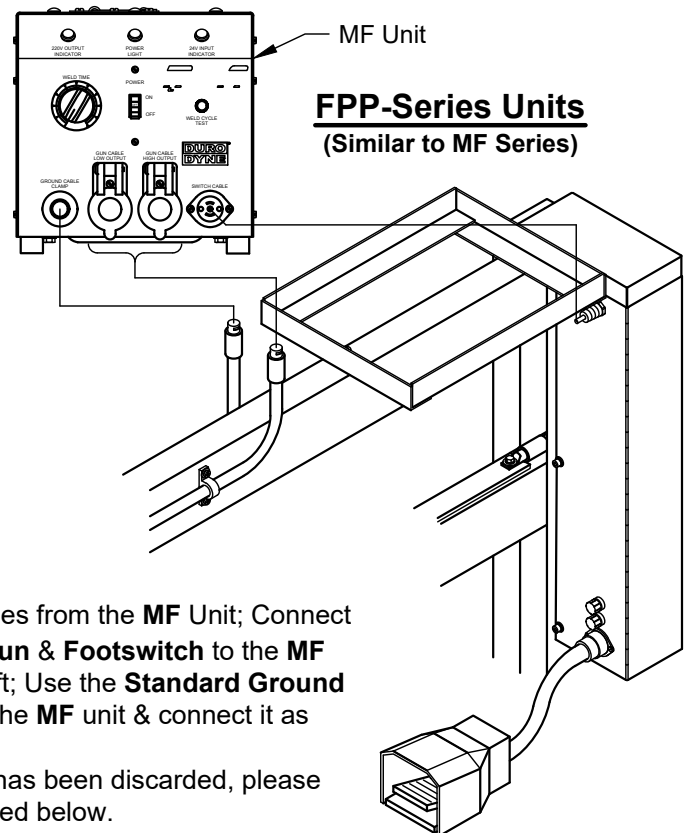
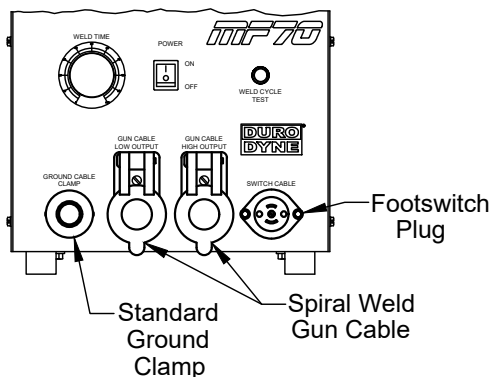

FPP Series Note: Detach the current cables from the MF Unit; Connect the new **Spiral Weld Gun & Footswitch** to the MF unit as shown above left; Use the **Standard Ground Clamp** that came with the MF unit & connect it as shown above left.

*If the **Ground Clamp** has been discarded, please order a new one as listed below.

Replacement Parts List

27055 Ground Extension
17372 Footswitch w/Guard

27063 90° Weld Tip Adapter
27056 SWG4.5 Copper Arm

27230 TP9 Weld Tip
27095 10ft Ground Clamp

Please contact our Technical Service Department with any questions at 631-249-9000

THE GREATEST NAME IN SHEET METAL NECESSITIES