

ROLLFORMER VS-150



The VS-150 is Roll Former's most versatile machine, capable of several different profiles. The VS-150 is equipped with hydraulic drive and front hydraulic scissors shear, 110 volt - 1 phase power, and 40 FPM speed. The base model produces a 1" and 1-1/2" Standing Seam profile and U-Panels, adjustable width panels of 9" - 24". The VS-150 is capable of forming 7 different profiles in total, from Snap Lock styles to true "Board and Batten" and Bermuda Roof profiles. The versatility is built into the design of the machine, but most importantly, the changeover time is as low as 15 minutes to 1 hour. Optional dies are available at any time, and a digital controller for fully automatic operation is also available and highly recommended for increased production.

Standard Features:

Quick and Easy Profile Changes

120V AC

40 FPM

Hydraulic Drive and Shear

Adjustable Width: 9" - 24"

Capacities:

22ga. Mild Steel

.032" Aluminum

12-20 oz. Copper

Options & Accessories:

Digital Controller

1"-1½" Snap Lock Dies

SOP-15 Dies

1"-1½" Bermuda Dies

Batten Pan Dies

Batten Cap Dies

Plus 50 Attachment

SSX or SSX-HD Seamer

Quick Release Rib Rolls



ROLLFORMER VS-150

Standard Profiles

U-Panel

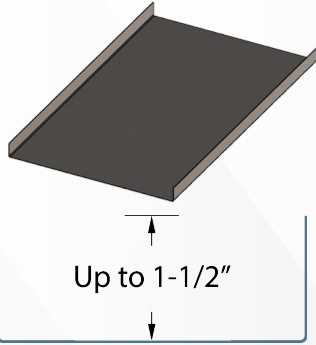

Mechanical Lock

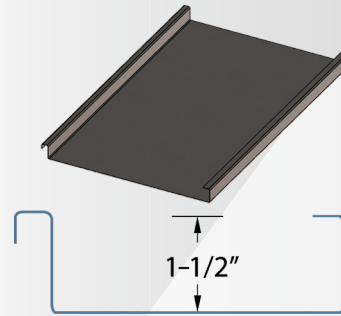

Optional Profiles

Snap Lock

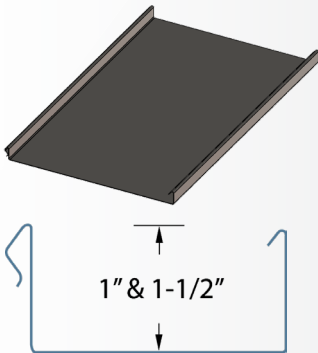

Batten Pan

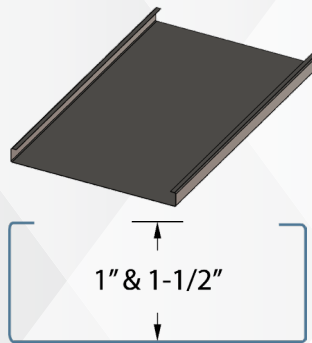

Batten Cap

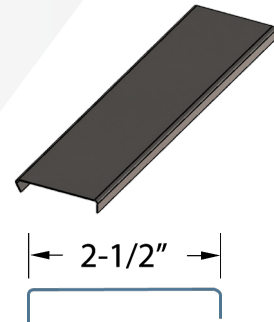

SOP 15

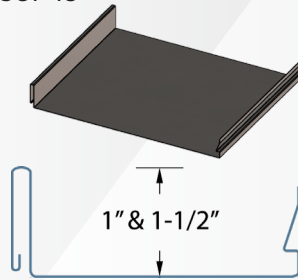

Bermuda Panel

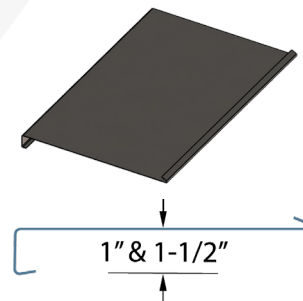

Options and Accessories

Striation

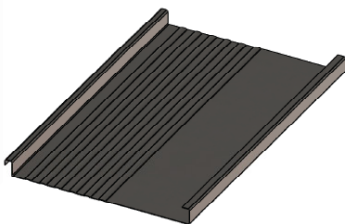

Clip Relief

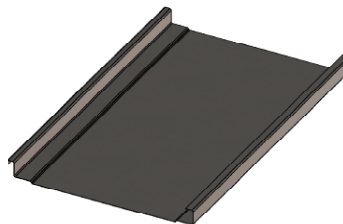

Plus 50

