

D U C T M A T E

**WDCI J & H**

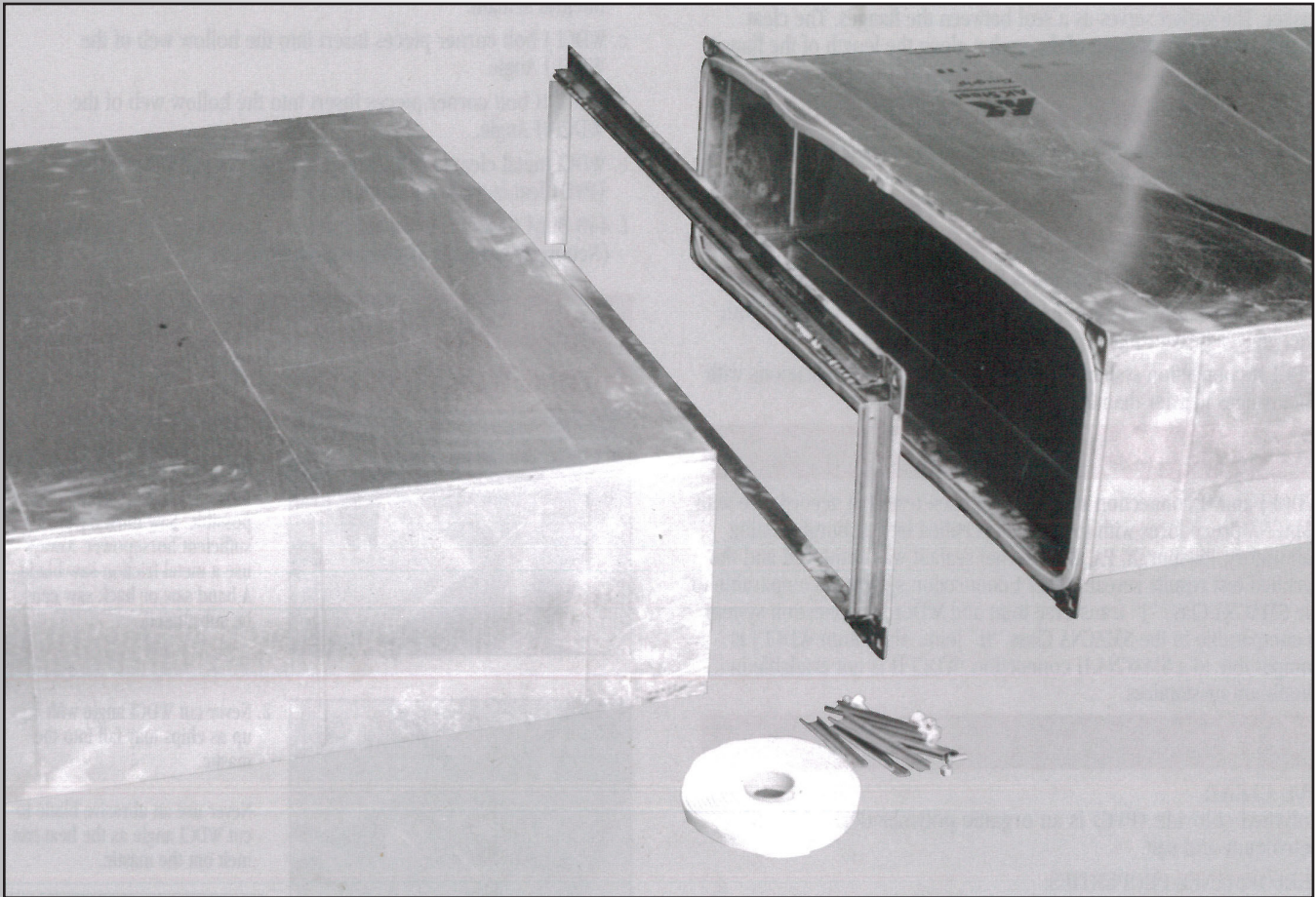

## Rectangular Duct Connection System

**Strong and Virtually Leak-Free**

- Simple to install
- No additional sealing required
- Available in specialty metals
- Consistent connections



**DUCTMATE<sup>®</sup>**  
**Industries, Inc.**

# WDCI J and H

## Rectangular Duct Connection System

### DESCRIPTION

WDCI J and H connection systems consist of roll-formed flanges, corner pieces, gasket, bolts, nuts and cleat. The flanges attach to the duct wall and have an integral mastic which allows the flange to seal itself to the duct. Corner pieces are used to add rigidity to the flange; hold the ductwork together and provide a sealing surface for the gasket. The gasket serves as a seal between the flanges. The cleat insures even compression of the gasket along the length of the flange.

### BASIC USE

WDCI J and H connection systems are used to connect rectangular ducts when a rigid, leak-free connection is required.

### SPECIAL CHARACTERISTICS

Sealing materials meet NFPA 90A & 90B Class 1 requirements.

WDCI J connections systems is not recommended for application with duct gauges heavier than 16 GA, or lighter than 26 GA.

WDCI H connection system is not recommend for applications with duct gauges heavier than 20 GA or lighter than 26 GA.

### TECHNICAL INFORMATION

WDCI J and H connection systems have been tested in accordance with SMACNA procedures with test results certified by Pittsburgh Testing Laboratory, Pittsburgh PA. No external sealant was employed and the certified test results reveal: WDCI J connection system is comparable to the SMACNA Class "J" transverse joint and WDCI H connection system is comparable to the SMACNA Class "H" joint. Aluminum WDCI J is comparable to a SMACNA H connections. WDCI H is not available in aluminum or stainless.

### CLEAT

#### PVC CLEAT:

Polyvinyl chloride (PVC) is an organic polymer derived from petroleum and salt.

#### PERFORMANCE PROPERTIES:

Relative high ignition resistance    flash ignition 391°C/735°F  
self ignition 454°C/850°F

Low fuel contribution

Lack of flaming drips

High external heat necessary to maintain combustion

UL723 (ASTM E-84) Test Data: Flame Spread: 10

Fuel Contribution: 0

Smoke Density: 10

Service Temp:

+32°F to +150°F

#### METAL CLEAT:

WDCI Metal Cleat is roll-formed from 22 GA galvanized steel for application around perimeter of transverse joint.

### PACKAGING INFORMATION

WDCI connection systems consists of the following components:

- WDCI J flange is roll-formed from 20 GA galvanized steel, with an integral sealant.
- WDCI H flange is roll-formed from 22 GA galvanized steel, with and integral sealant.
- WDCI J bold corner pieces insert into the hollow web of the WDCI J Angle.
- WDCI H bold corner pieces insert into the hollow web of the WDCI H Angle.
- WDCI metal cleat is roll-formed from 22 GA galvanized steel (PVC Cleat is available upon request).
- 440 Butyl Gasket is extruded butyl for used between mating flanges (Neoprene gasket is available upon request).

### INSTALLATION INSTRUCTIONS

#### Cutting WDCI Angle

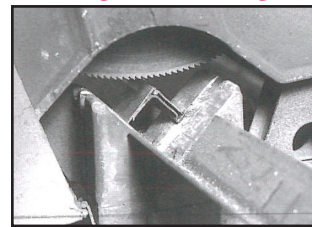

- Always cut WDCI angle  $1\frac{5}{16}$ " shorter than duct dimensions. Slam the blade through the Angle as quickly as possible. Saw must have sufficient horsepower. Always use a metal friction saw blade. A band saw or hack saw can be substituted.

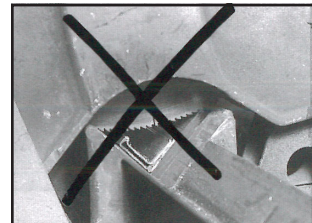

- Never cut WDCI angle with legs up as chips may fall into the mastic. Never use abrasive blade to cut WDCI angle as the heat can melt out the mastic

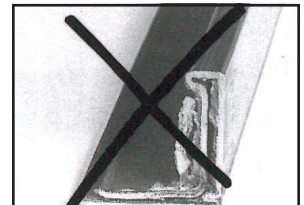

#### Assembling WDCI Frame

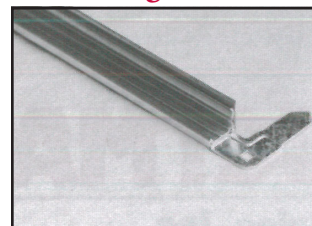

- Insert a WDCI corner piece into each end of the two shortest frame angle pieces.

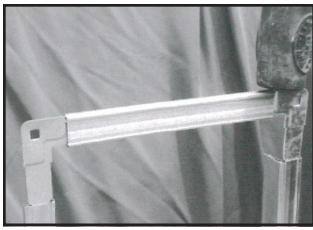

4. Slide two longer angle pieces onto corner pieces already inserted into shorter pieces, then add the second short piece to complete the frame.

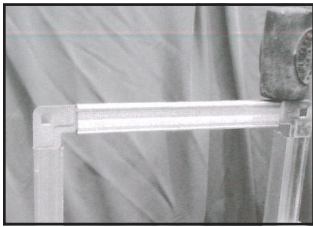

5. Now complete the frame by seating the corner pieces into the WDCI angle.

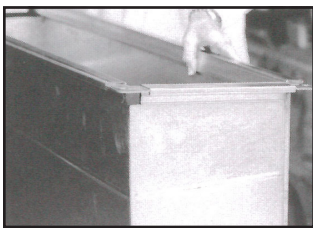

6. Start, completed WDCI frame at corner of duct.

### Seating WDCI Frame

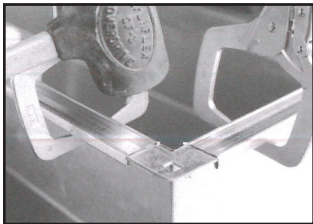

7. Use a mallet to seat the frame onto the duct. *Establish metal to metal contact along the length of the angle.*

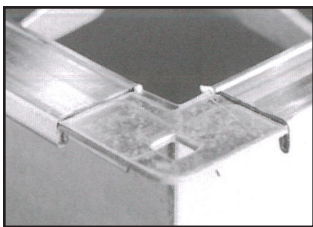

8. The duct must be seated all the way into the WDCI angle in order to penetrate the integral mastic sealant and avoid leakage.

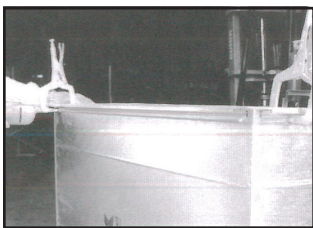

9. Work in one direction around duct when seating the frame. Fasten in sequence as you go. Do not fasten angle at corners first, it can cause seating problems.

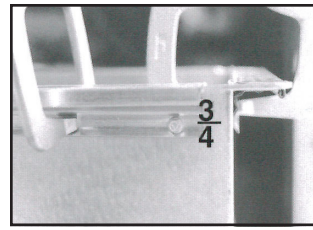

10. It is essential that the frame angle is fastened to the duct within  $\frac{3}{4}$ " of the end of the angle at each corner.

When the table below requires a second screw at each corner it must be placed within 2"-3" of the end of the WDCI angle.

WDCI angle may be fastened to the duct with self drilling screws or spotwelds.

Spot welding is recommended, especially on ductwork where static pressure is above 3" and the leakage is specified to be less than 1%.

Due to their superior strength, spotwelds may be substituted for screws in the table below. Table also shows minimum fastening requirements. Job conditions (handling, etc.) may require additional fastening.

Fasten at intervals as in table below:

Duct Wall Size	0-4" W.G.	6" W.G.
0-24"	1 screw each corner	1 screw each corner
25"-48"	1 screw each corner	2 screws each corner
49" and over	1 screw each corner plus 1 screw each 24"	2 screws each corner plus 1 screw each 24"

### Applying Ductmate 440 Gasket Tape

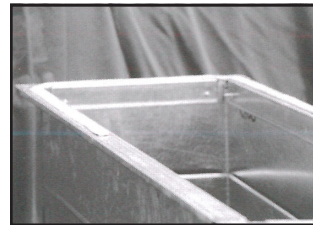

11. Start approximately in the middle of one side, place a single strip of gasket tape completely around the inside edge of the angle frame. At the corners, the gasket must cover the exposed edge of the duct section and the gap between the duct wall and the WDCI corners.

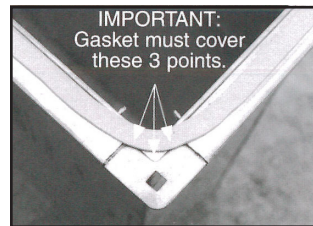

12. Position 440 Gasket in an arc so that it covers the three points in the duct corner. Gasket must cover all three points. Some gasket will protrude into the airstream. Press firmly into contact with the raw edge of the duct corner and WDCI corner assembly. In steps 11, 12, 13, and 14 Ductmate 440 is the preferred gasket. Ductmate Neoprene Gasket may be used where a section must be disassembled.

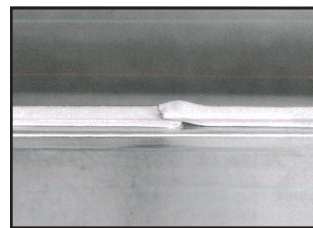

13. Apply 440 gasket completely around WDCI frame to the beginning point. Where the gasket meets overlay about  $\frac{3}{8}$ ".

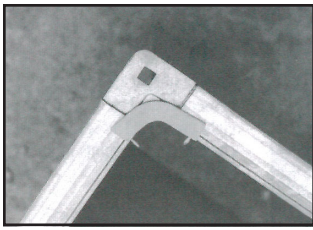

14. On the mating WDCI frame apply 440 gasket only to the corners as in photo (approximately 3" per corner). The same 3 point application requirements apply as in photo 12.

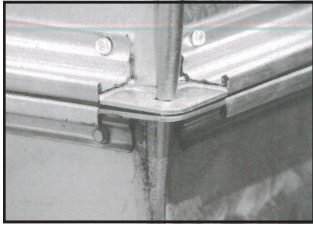

15. Carefully align mating frames before they touch. Ductmate 440 adheres on contact. A drift pin can be used to correct any misalignment.

### Completing WDCI Connection

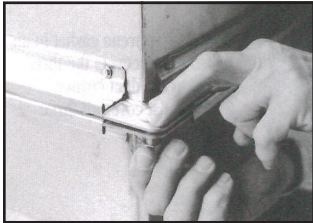

16. Insert  $\frac{3}{8}$ " x 1" nut and bolt for WDCI J Connection System.  
Insert a  $\frac{1}{4}$ " x 1" nut and bolt for WDCI H Connection Systems.  
It is not necessary to over torque the nuts and bolts.

### Cleat Installation

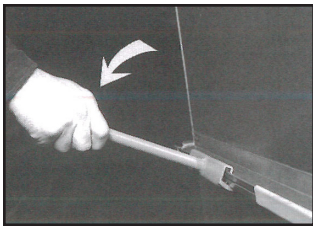

**With DM440 Gasket**  
For all low, medium and high pressure applications, use 6" cleat 24" O.C.

**With Neoprene Gasket**  
For  $\frac{1}{2}$ " - 2" WG/SP use 6" cleat, 24" O.C.  
For 3" - 4" WG/SP use 6" cleat, 18" O.C.  
For 6" - 10" WG/SP use 6" cleat, 12" O.C.

17. WDCI cleat can be snapped-on with the Snapper1 Tool.  
Insert cleat in tool, hook onto mated frames near corner, apply pressure to handle so the Snapper tool compresses frames and cleat snaps on. Work toward center of duct using the schedule at left.  
For weather-proof duct connections, install full-length, one-piece cleat to top duct flange joint to prevent water from collecting on gasket.  
If corner cannot be bolted due to inaccessibility, cleat can be driven onto the mating flanges to complete the WDCI connection.



**SNAPPER1**  
Ideal tool to attach cleat to WDCI flange joint.

## DUCTMATE WDCI COMPONENTS

### WDCI H Corner Piece

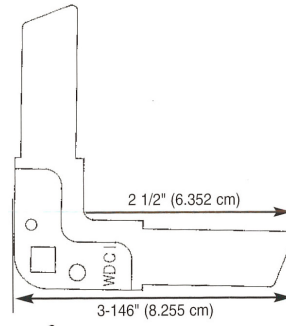

### WDCI J Corner Piece

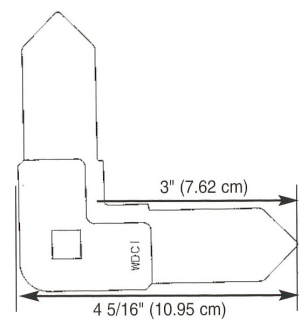

### Press-On Bullnosing

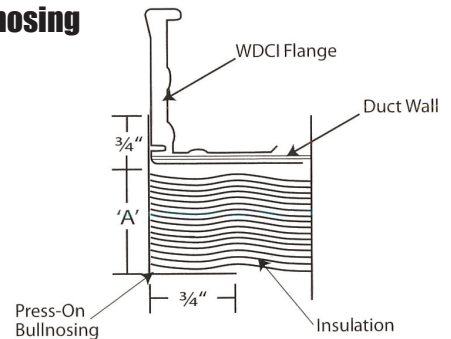

### WDCI H

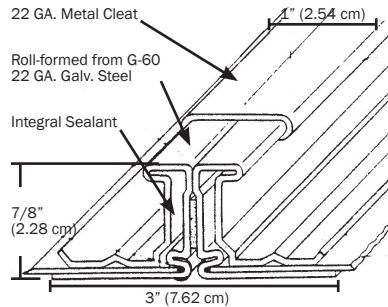

### WDCI J

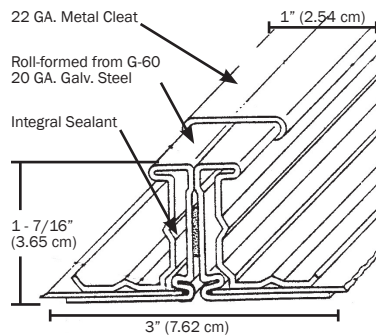

## ADDITIONAL INSTRUCTION FOR APPLICATION REQUIRING NEOPRENE GASKET

When using Neoprene gasket with WDCI J & H connection system, sealant is required in the corners. Unlike the Butyl gasket the Neoprene gasket alone is unable to properly seal the corners. It is necessary to apply a small amount of duct sealant (preferably sealant from a tube) in all eight corners to form a flawless connection. Ideally the sealant should be allowed to cure before the gasketing is applied. However, if reasonable care is taken, the gasket may be applied before the sealant is cured. When applying the gasket, care must still be taken at the corners. As with the 440 Butyl gasket, the three points at the corners should be covered. The joint is then completed in the standard manner. This sealing technique is especially useful when making connections at fire dampers where the Neoprene must be used.

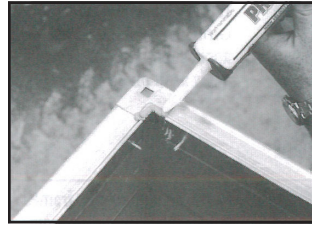

1. Apply a liberal amount of PROseal sealant in each of the eight corners. The sealant must cover the three points in the duct corner.

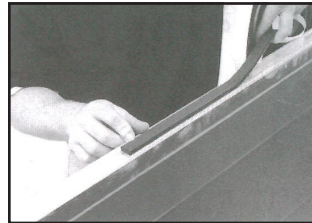

2. Start applying Ductmate Neoprene gasket about halfway between corners. Position gasket in center of WDCI angle as in photo.

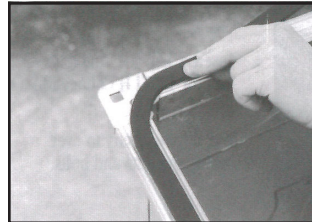

3. Position Neoprene gasket in an arc so that it covers the three points in the duct corner. Gasket must cover all three points.

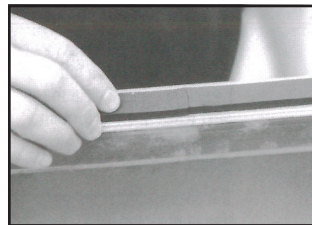

4. Apply Neoprene gasket completely around WDCI frame to the beginning point. Butt the two ends of the gasket up against each other. Do not overlap the two ends.

Frequently a contractor installing a high velocity duct system will employ a duct joint which either he or his work force have no experience. In such a case, it is strongly recommended that the contractor promptly test the initial 100 to 300 feet of duct before installing any more duct. This test will quickly reveal whether or not the workmen can make this joint airtight in an economical manner.

*Reprinted from SMACNA High Pressure Manual*

# LIMITED PRODUCT WARRANTY

Ductmate warrants that WDCI J and H Connection Systems, when properly installed and maintained, will be free from defects in material and workmanship, and will comply with all written specifications made by Ductmate at the time of sale. Ductmate's warranty shall run for a period of one year from the date of manufacture.

### Warranty Limitation

The warranty stated above is in lieu of all other warranties, express or implied, including but not limited to the implied warranties of MERCHANTABILITY AND FITNESS FOR A PARTICULAR PURPOSE. Although Ductmate may have suggested the product, or provided written or oral advice to the Purchaser, it is the Purchaser's responsibility to test and determine the suitability of WDCI J and H Connection Systems, for the intended use and purpose, and Purchaser and/or its customer assumes all risk and liability whatsoever regarding such suitability.

### Limitation of Liability

In the event of a breach of the above warranty, Ductmate's sole obligation, and Purchaser's sole and exclusive remedy, shall be, at Ductmate's option, repair or replacement of any defective products, or refund of an applicable portion of the purchase price. Ductmate shall have no liability for costs of removal or reinstallation of the product. The Purchaser agrees that no other remedy, including but not limited to loss of profits, loss sales, injury to person or property, or any other special, incidental or consequential damages, shall be available to the Purchaser for any claim arising out of this Agreement, regardless of whether such claim is made in contract or in tort, including strict liability in tort. In no event will Ductmate be obligated to pay damages to the Purchaser in any amount exceeding the purchase price that the Purchaser paid to Ductmate for the allegedly defective product.



**Charleroi, PA**      **Lodi, CA**  
210 Fifth Street      810 S. Cluff Avenue  
Charleroi, PA 15022      Lodi, CA 95240-9141  
724-258-0500      209-333-4680

*Additional Manufacturing and Warehousing in  
Monongahela, PA and Wagoner, OK*

1-800-245-3188 • [www.ductmate.com](http://www.ductmate.com)

© Copyright Ductmate Industries, Inc. All rights reserved.



Ductmate Is A Proud Member Of The Following Organizations:



Distributed By: